

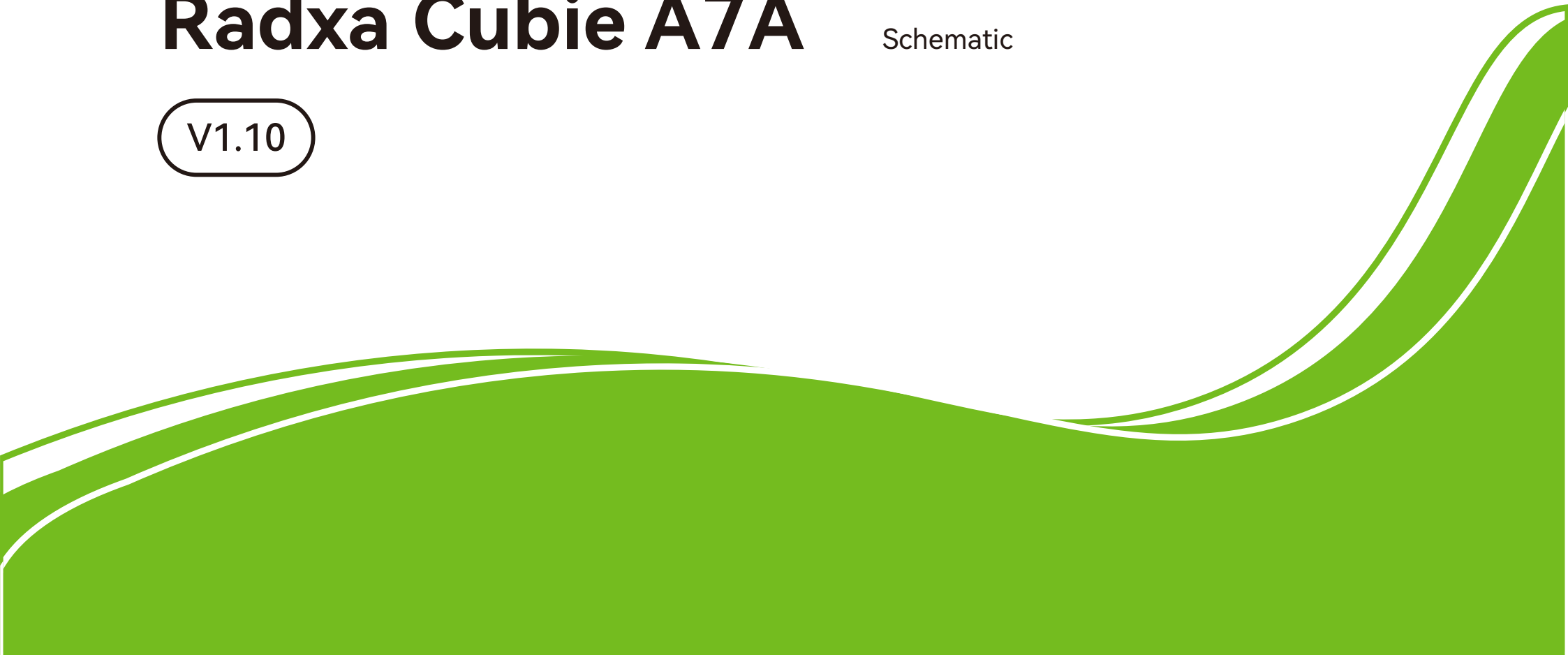

# Radxa Cubie A7A

Schematic

V1.10



# Index

Page 1	01.Cover
Page 2	02.Index
Page 3	03.Block
Page 4	04 POWER AXP318
Page 5	05 LPDDR5 32X1
Page 6	06 A733 Analog&High-speed
Page 7	07 A733 GPIO
Page 8	08 A733 SYS
Page 9	09 EMMC_UFS_NOR
Page 10	10 MIPI LCM/CTP
Page 11	11 CAMERA
Page 12	12 AUDIO AC101
Page 13	13 WIFI/BT
Page 14	14 USB20_USB30
Page 15	15 USBC0_T-CARD
Page 16	16 PCIE_40PIN_CONNECT
Page 17	17.HDMI
Page 18	18 ETHERNET
Page 19	19 KEY_LED_RTC_FAN



Size	Title: RS501	REV
A4	Page Name: 02 INDEX	V1.10
Date: Monday, April 28, 2025	Sheet 02 of 19	

# BLOCK

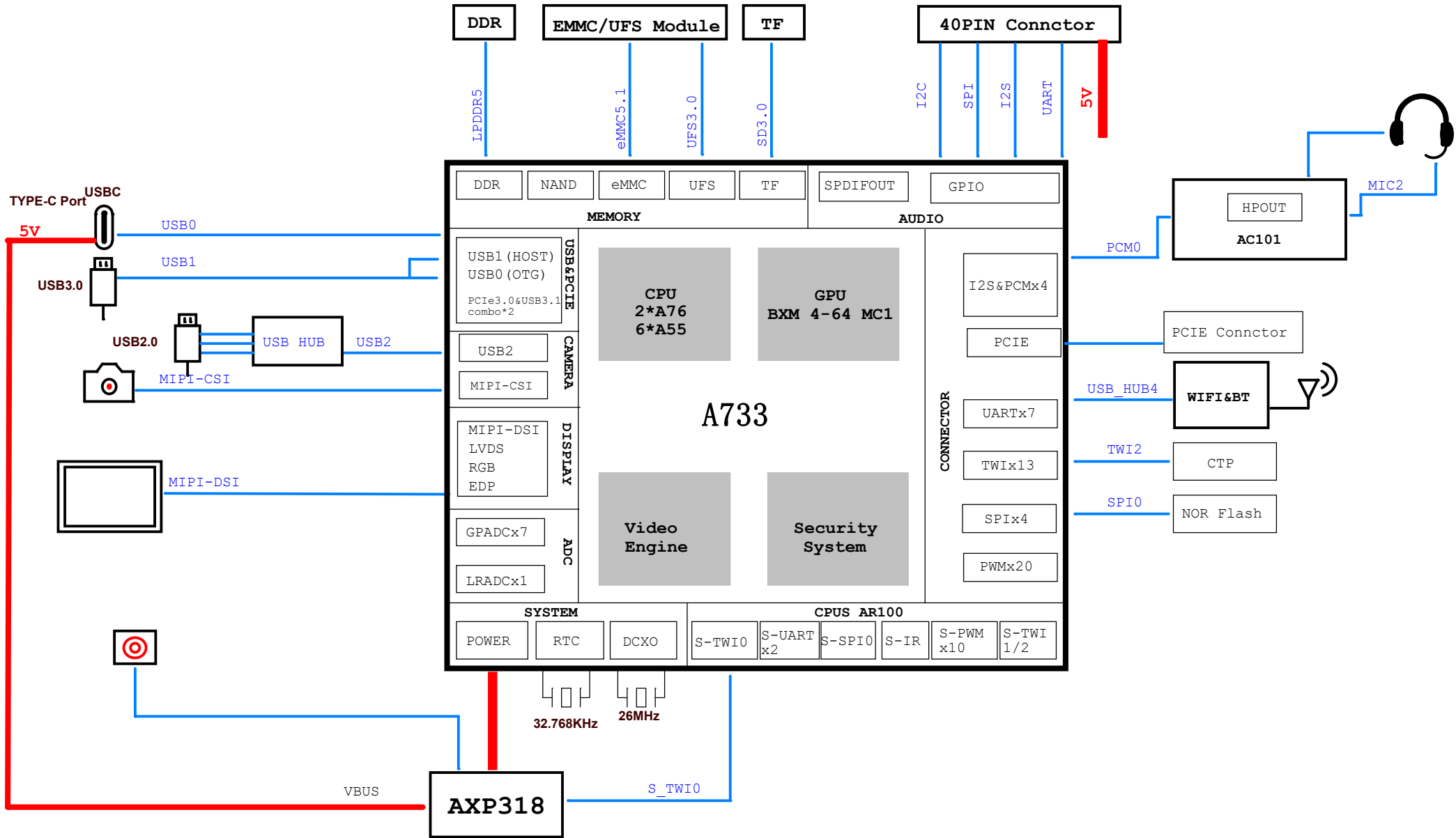



# LPDDR5

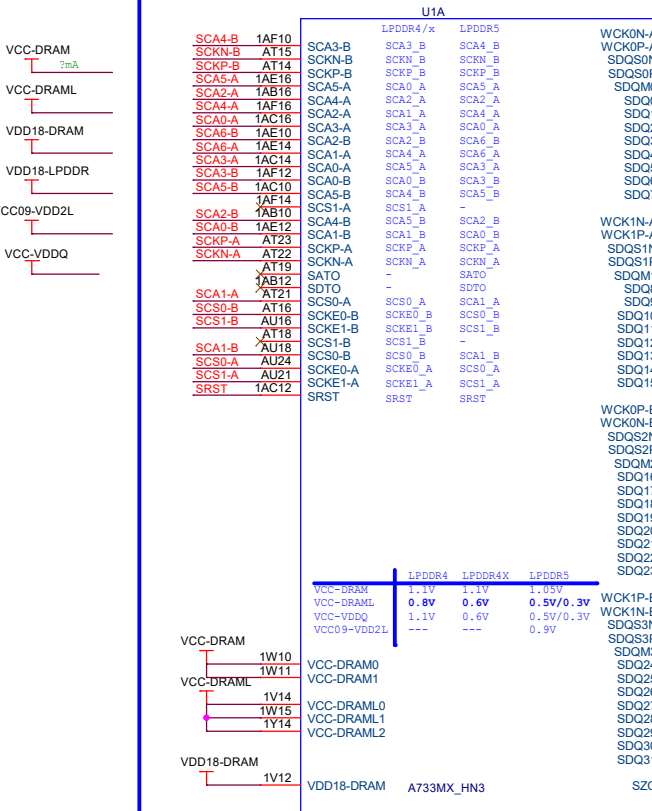

	LPDDR4	LPDDR4X	LPDDR5
VCC-DRAM	1.1V	1.1V	1.05V
VCC-DRAML	0.8V	0.6V	0.5V/0.3V
VCC-VDDQ	1.1V	0.6V	0.5V/0.3V
VCC09-VDD2L	---	---	0.9V

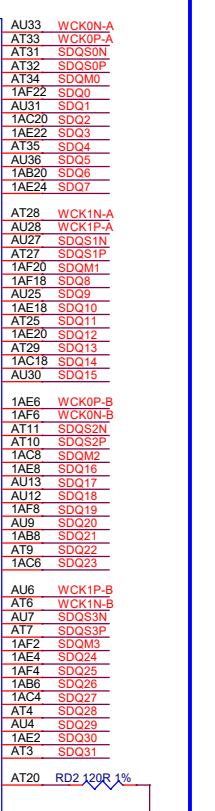
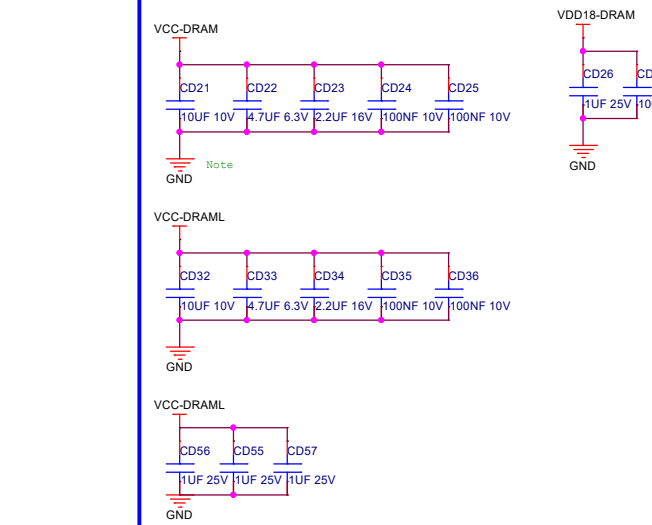

	LPDDR4	LPDDR4X	LPDDR5
VCC-DRAM	1.1V	1.1V	1.05V
VCC-DRAML	0.8V	0.6V	0.5V/0.3V
VCC-VDDQ	1.1V	0.6V	0.5V/0.3V
VCC09-VDD2L	---	---	0.9V

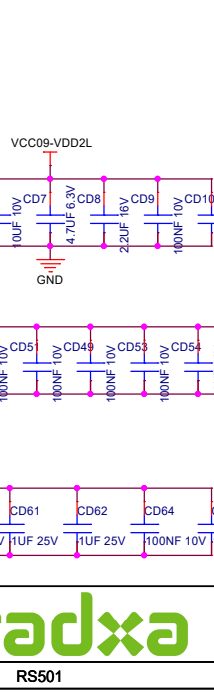
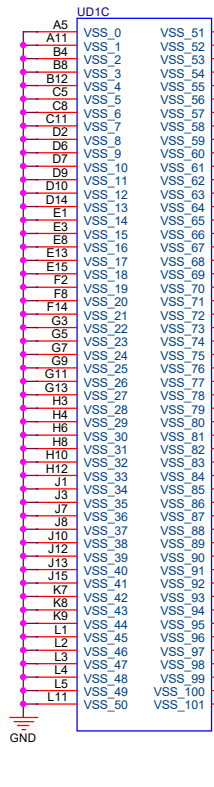
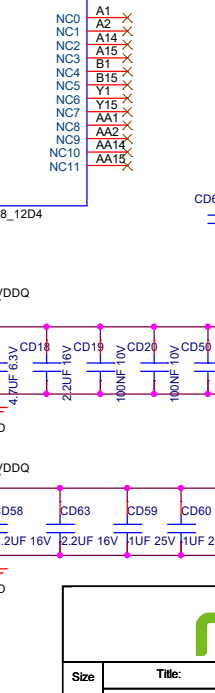
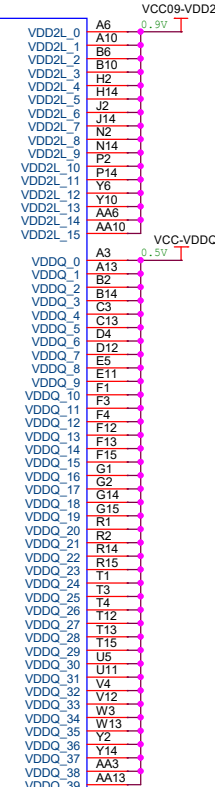
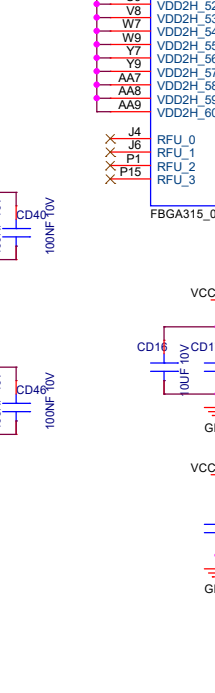
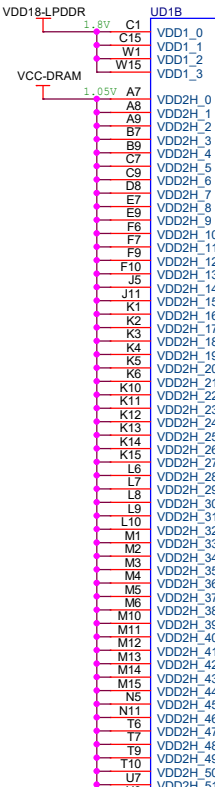
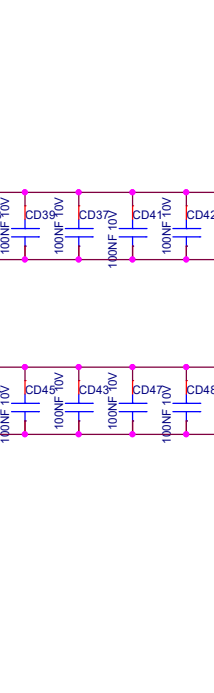
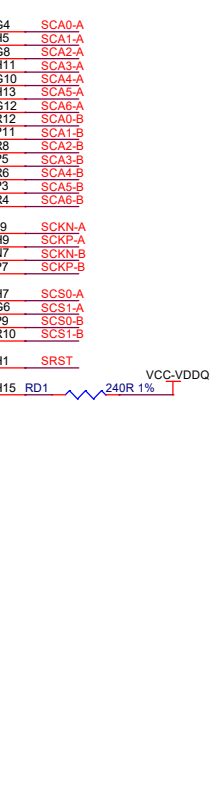
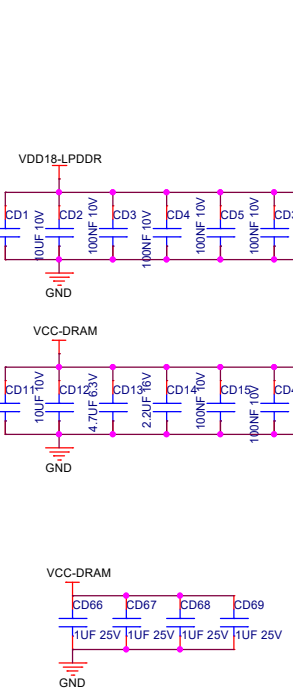
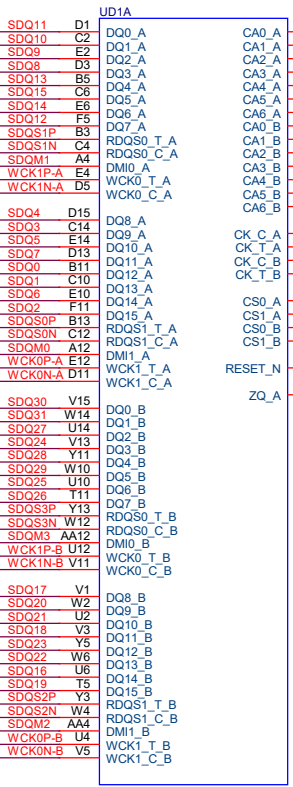
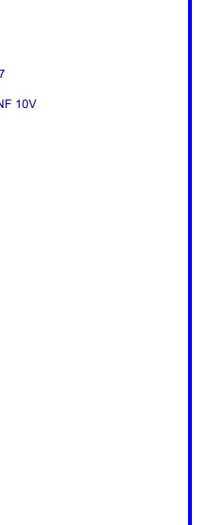

# ADC

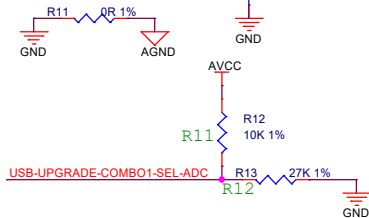
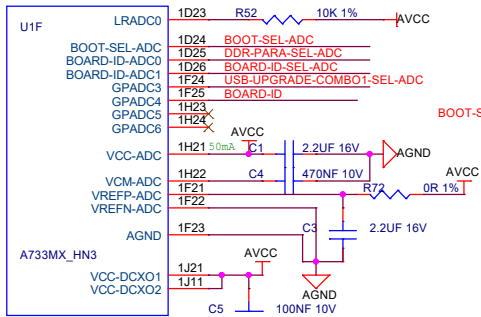

BOOT-SEL-ADC			Boot Media Type Select	
R1-1%	R2-1%	Volt		
NC	10K	0mV	SMHC0->MLC NAND->SLC NAND->TRY (except SPI4 in PI)	
10K	1K	163mV	SMHC0->SLC NAND->MLC NAND->TRY (except SPI4 in PI)	
10K	2K2	325mV	SMHC0->EMMC_USER->EMMC_BOOT->TRY (except SPI4 in PI)	
10K	3K9	505mV	SMHC0->EMMC_BOOT->EMMC_USER->TRY (except SPI4 in PI)	
6K8	4K7	736mV	SMHC0->SPI0 NOR->TRY (except SPI4 in PI)	
6K8	6K8	900mV	SMHC0->SPI0 NAND->TRY (except SPI4 in PI)	
4K3	6K8	1102mV	SMHC0->SPI4 NOR in PI->TRY (except SPI4 in PI)	
2K2	10K	1475mV	SMHC0->SPI4 NAND in PI->TRY (except SPI4 in PI)	
10K	NC	1800mV	SMHC0->UFS->TRY (except SPI4 in PI)	

R11	R12	Volt	Upgrade	COMBO1
10K-1%	1K-1%	163mV		PCIE
	2K7-1%	382mV		USB
	5K1-1%	608mV		Floating
	27K-1%	1315mV	USB0	PCIE
	68K-1%	1569mV	USB0	USB
	NC	1800mV	USB0	Floating

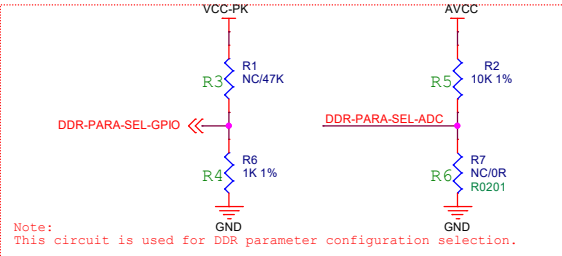
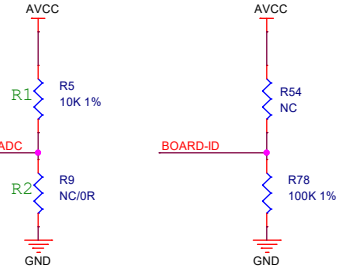

Note: This circuit is used for DDR parameter configuration selection.

GPIO-SET	BOARD-ID-SEL-ADC	DDR PARA
0	163mV (1K-1%)	4GB H
0	382mV (2.7K-1%)	6GB H
0	608mV (5.1K-1%)	8GB H
0	811mV (8.2K-1%)	12GB H
0	1050mV (14K-1%)	DDR PARA 5
0	1315mV (27K-1%)	DDR PARA 6
0	1569mV (68K-1%)	DDR PARA 7
0	1800mV (NC)	4GB HY
1	163mV (1K-1%)	DDR PARA 9
1	382mV (2.7K-1%)	DDR PARA 10
1	608mV (5.1K-1%)	DDR PARA 11
1	811mV (8.2K-1%)	DDR PARA 12
1	1050mV (14K-1%)	DDR PARA 13
1	1315mV (27K-1%)	DDR PARA 14
1	1569mV (68K-1%)	DDR PARA 15
1	1800mV (NC)	DDR PARA 16

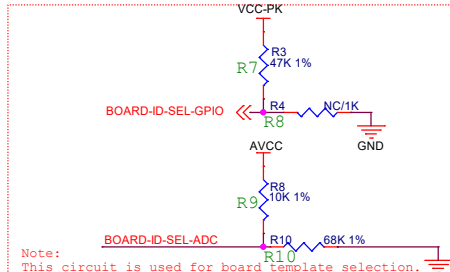

Note: This circuit is used for board template selection.

GPIO-SET	BOARD-ID-SEL-ADC	BoardID Config
NC	1K pull down	1K-1% 163mV Config-1
		2K7-1% 382mV Config-2
		5K1-1% 608mV Config-3
		8K2-1% 811mV Config-4
		14K-1% 1050mV Config-5
		27K-1% 1315mV Config-6
		68K-1% 1569mV Config-7
		NC 1800mV Config-8
47K pull up	10K-1%	1K-1% 163mV Config-9
		2K7-1% 382mV Config-10
		5K1-1% 608mV Config-11
		8K2-1% 811mV Config-12
		14K-1% 1050mV Config-13
		27K-1% 1315mV Config-14
		68K-1% 1569mV Config-15
NC 1800mV Config-16		

# USB&EDP&PCIE

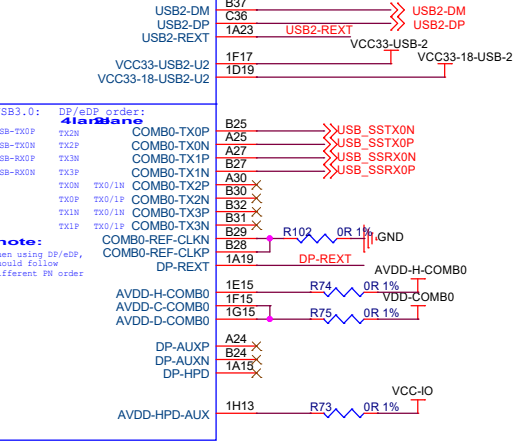
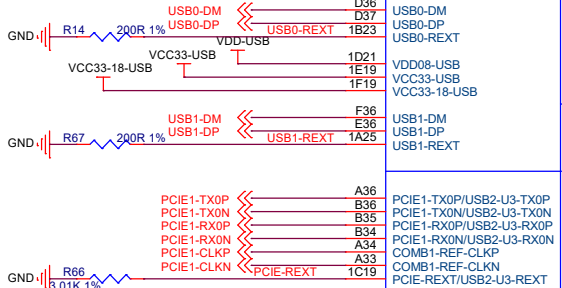

# UFS

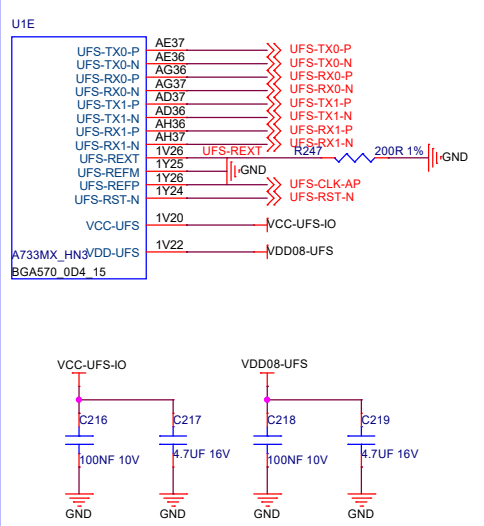

# HDMI

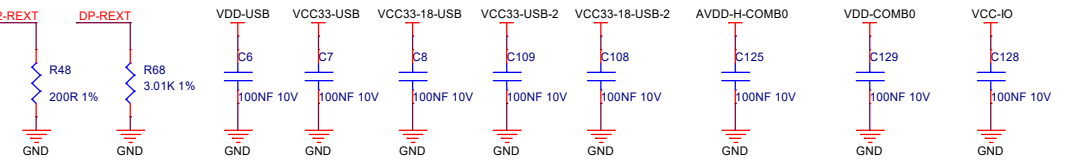
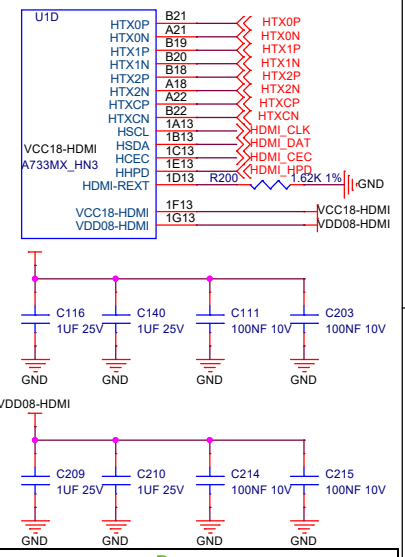

Size	Title:	RS501	REV
A3	Page Name:	06 A733 Analog&High-speed	V1.10
Date:	Thursday, July 10, 2025	Sheet	06 of 19





# eMMC/UFS/NOR FLASH

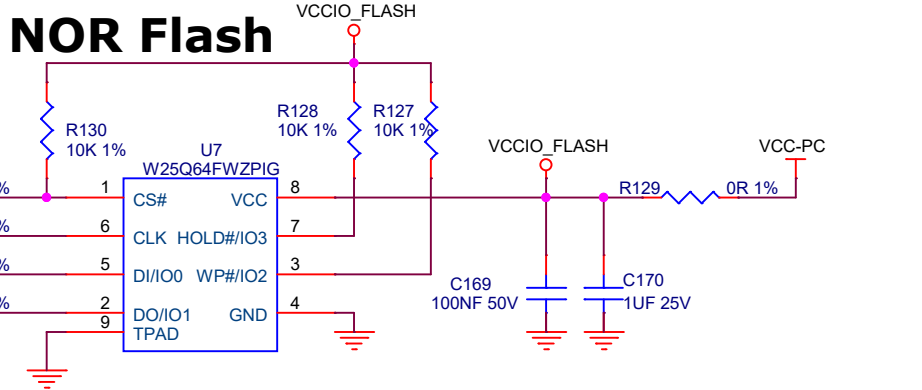
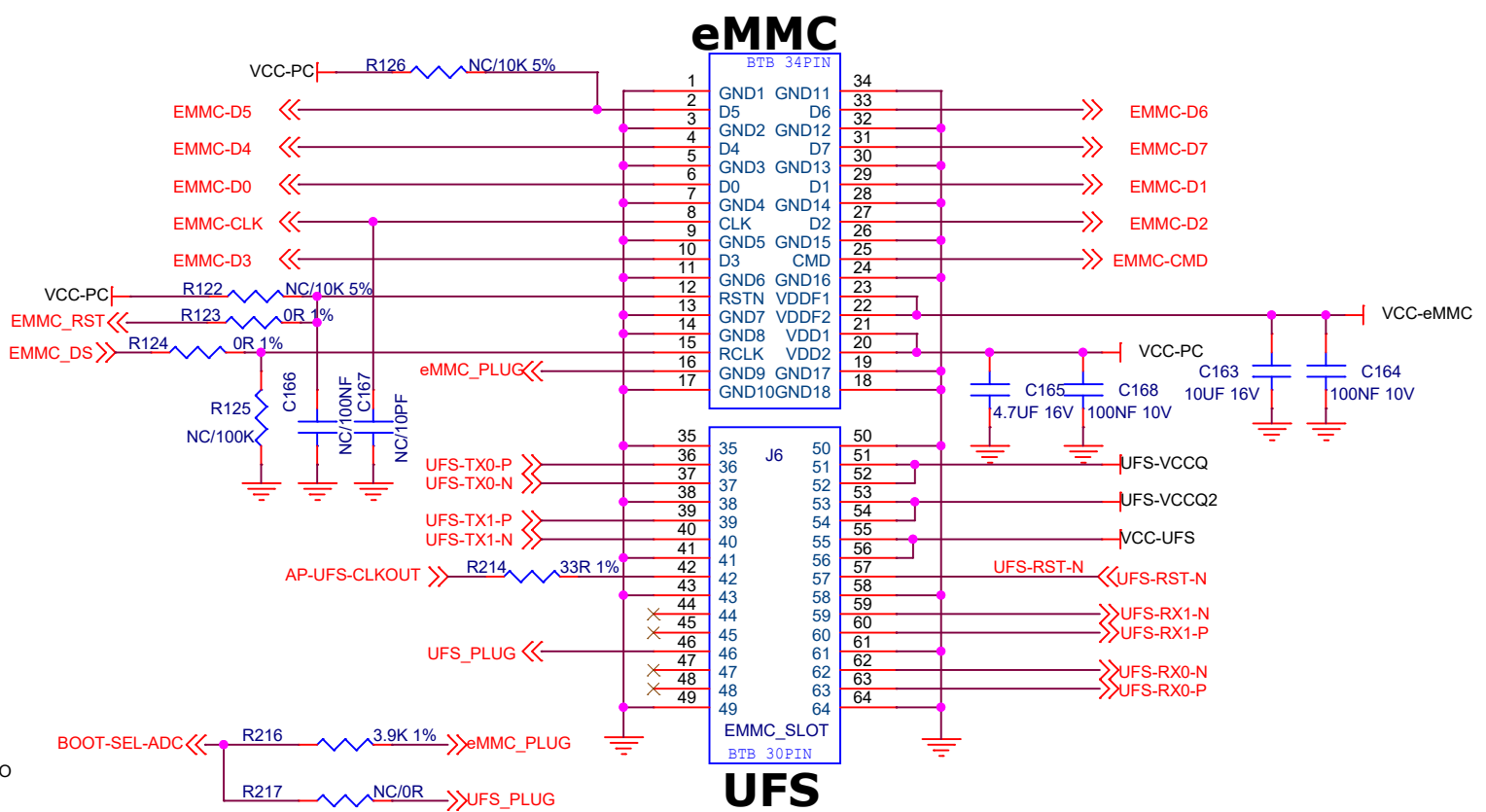
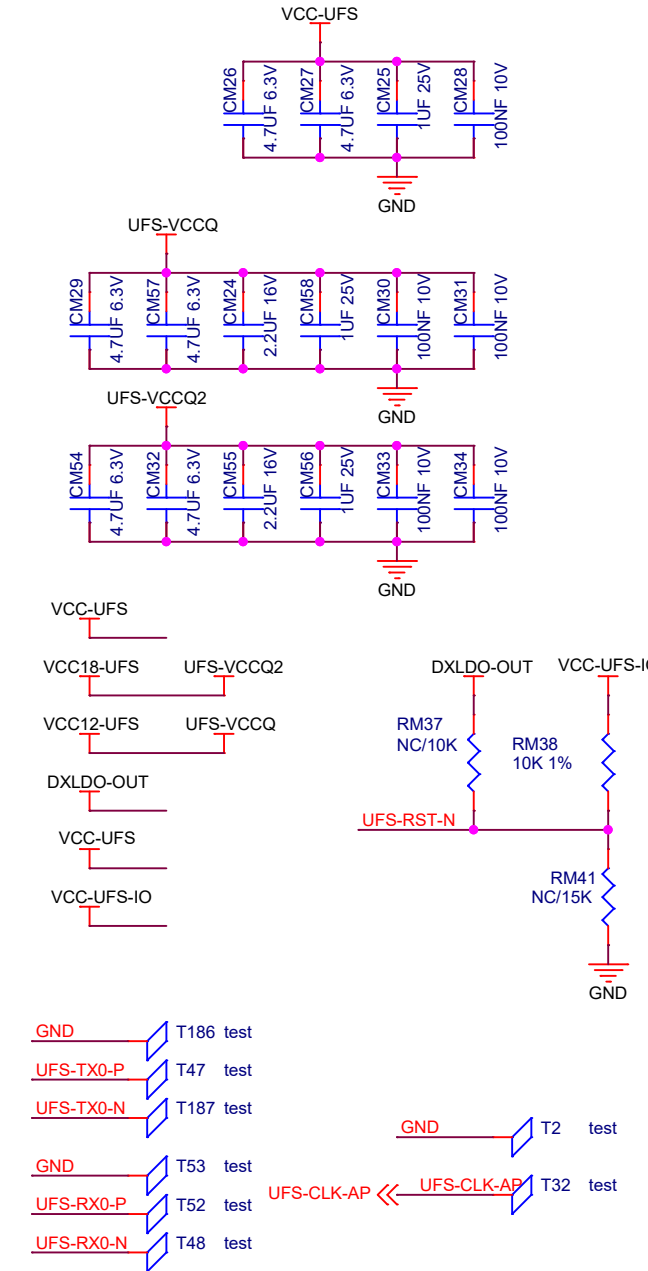

**radxa**

Size	Title: RS501	REV
A4	Page Name: 09 EMMC_UFS_NOR	V1.10
Date: Tuesday, July 29, 2025	Sheet 09 of 19	

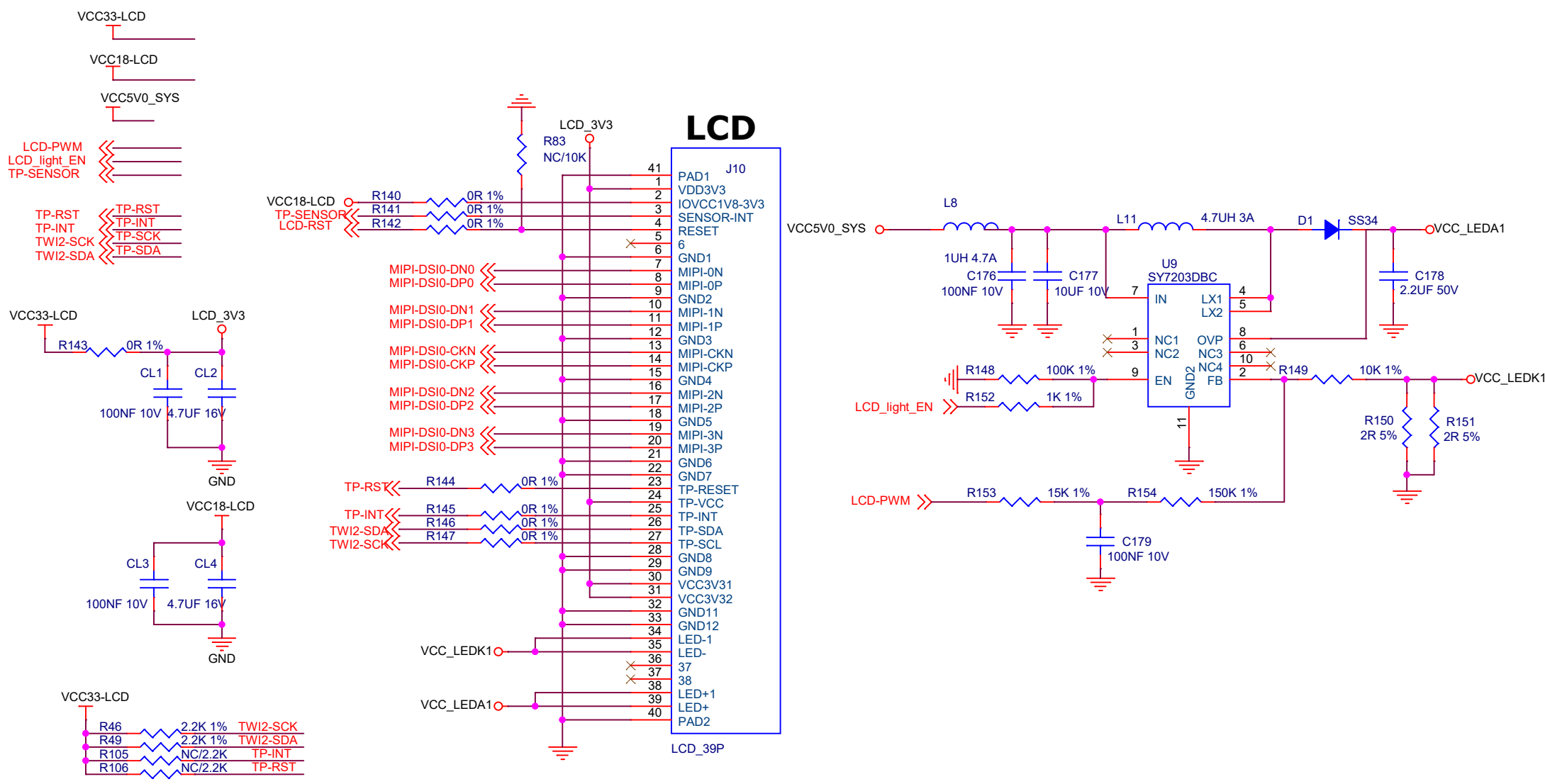

**radxa**

Size	Title: RS501	REV
A4	Page Name: 10 MIPI LCM/CTP	V1.10
Date: Monday, April 28, 2025	Sheet 10 of 19	

# CAMERA

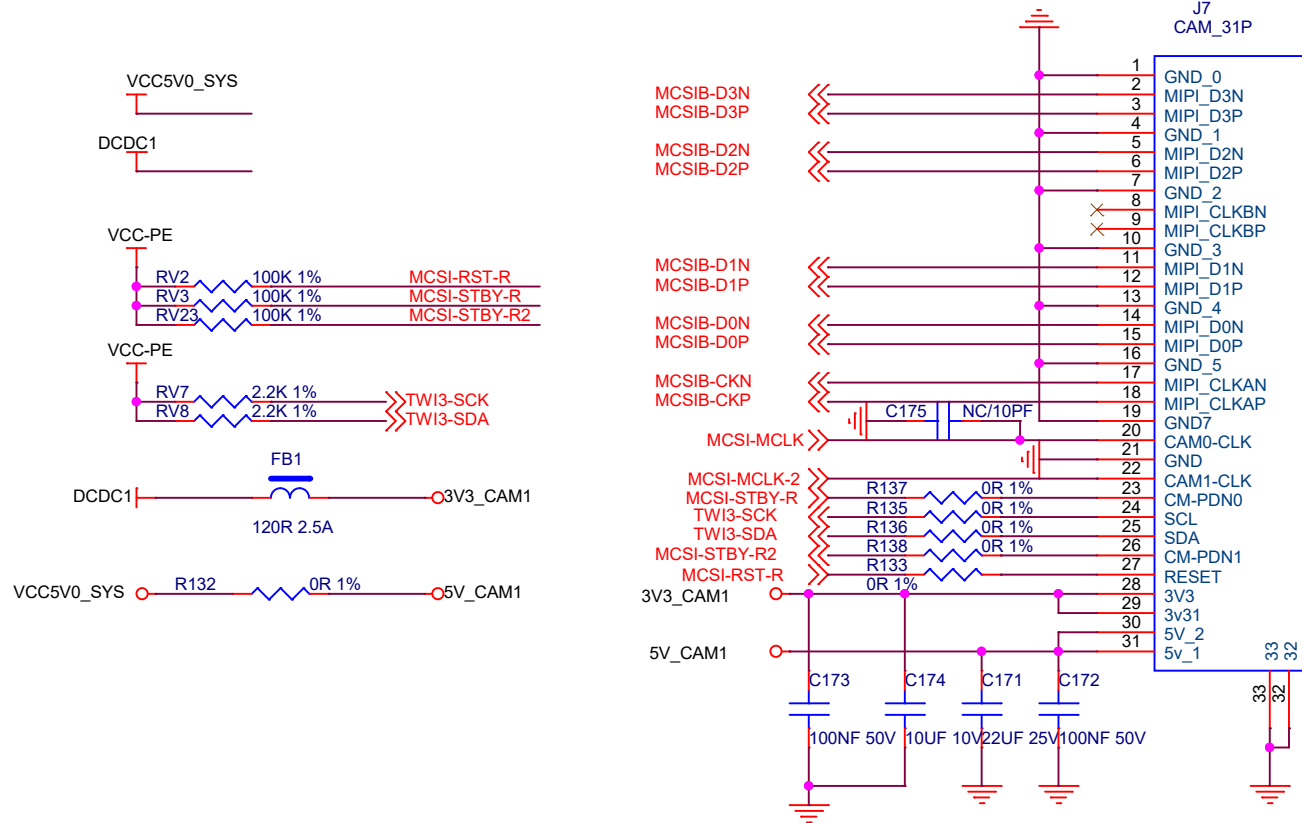

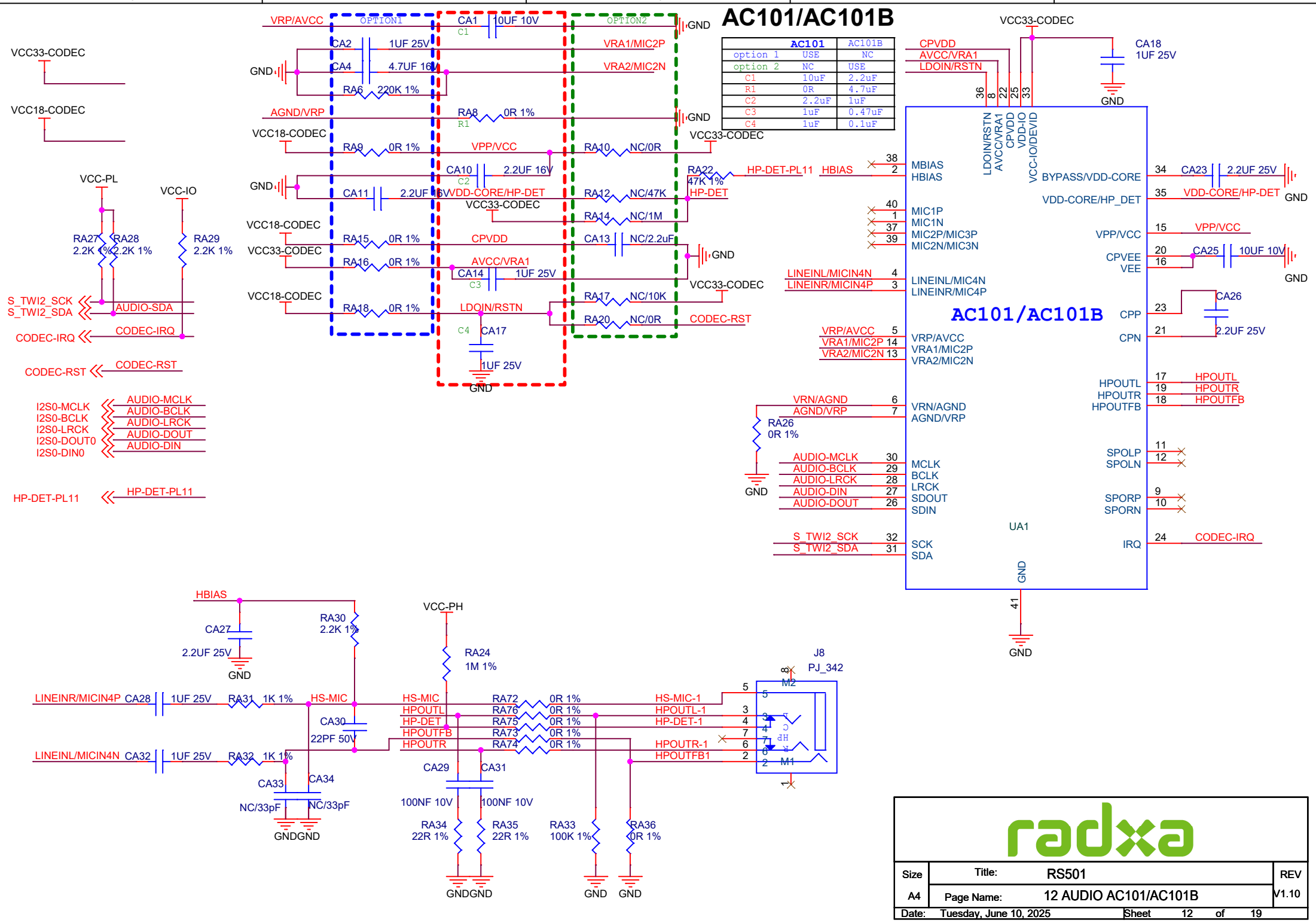

Size	Title: RS501	REV
A4	Page Name: 11 CAMERA	V1.10
Date: Monday, April 28, 2025	Sheet 11 of 19	

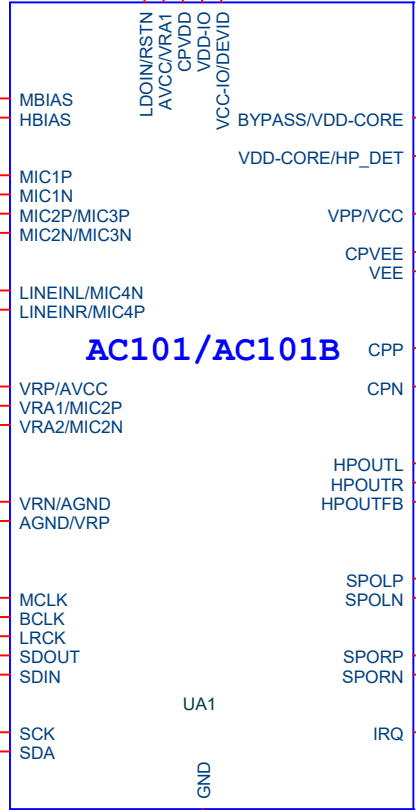

# AC101/AC101B

	AC101	AC101B
option 1	USE	NC
option 2	NC	USE
C1	10uF	2.2uF
R1	0R	4.7uF
C2	2.2uF	1uF
C3	1uF	0.47uF
C4	1uF	0.1uF





Size	Title: <b>RS501</b>		REV
	Page Name: <b>12 AUDIO AC101/AC101B</b>		
A4	Date: <b>Tuesday, June 10, 2025</b>		Sheet <b>12</b> of <b>19</b>

# WIFI/BT

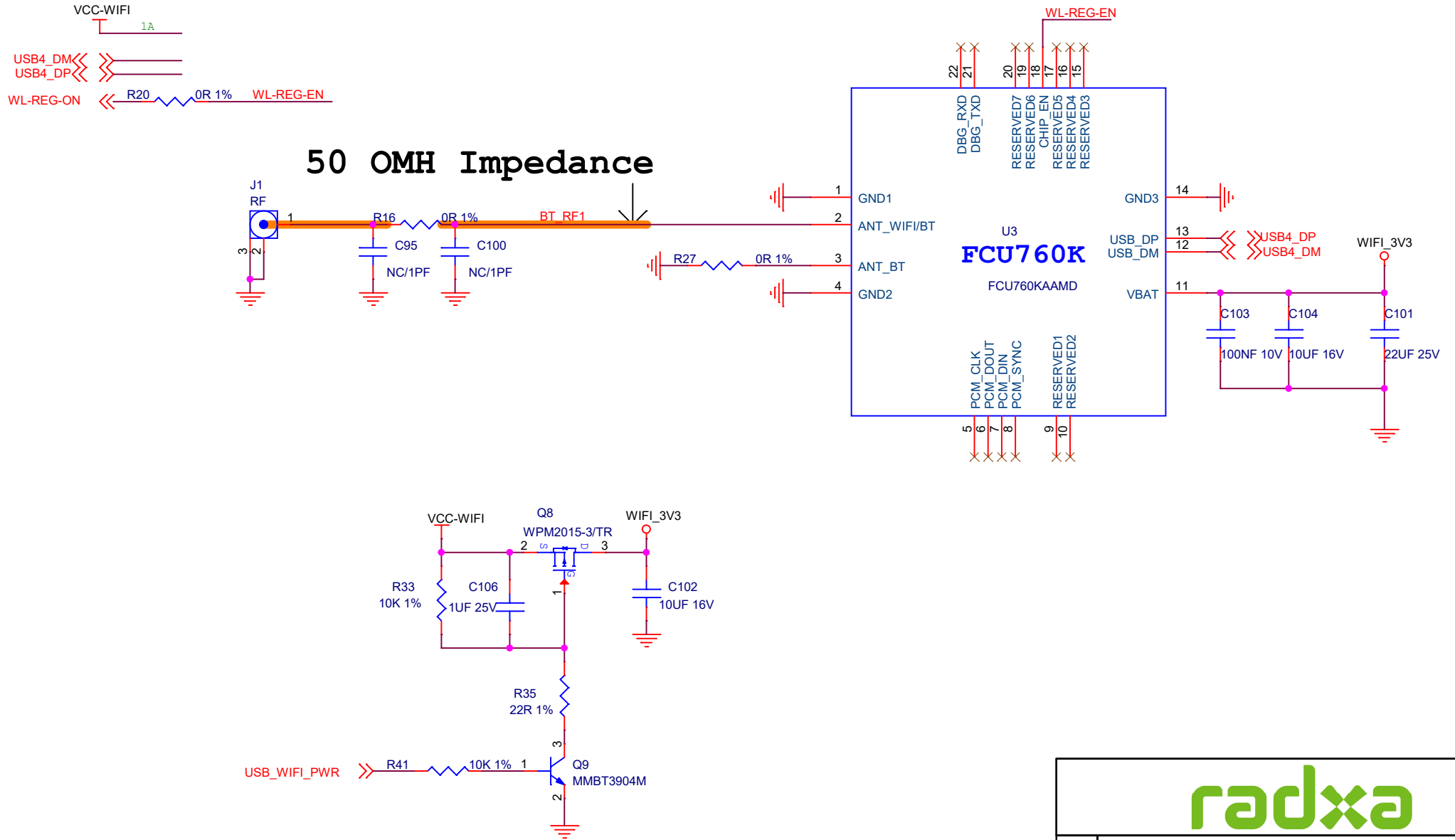

**radxa**

Size	Title: <b>RS501</b>	REV
A4	Page Name: <b>13 WIFI/BT</b>	V1.10
Date: <b>Monday, April 28, 2025</b>	Sheet <b>13</b> of <b>19</b>	

# USB3.0 /2.0/HUB

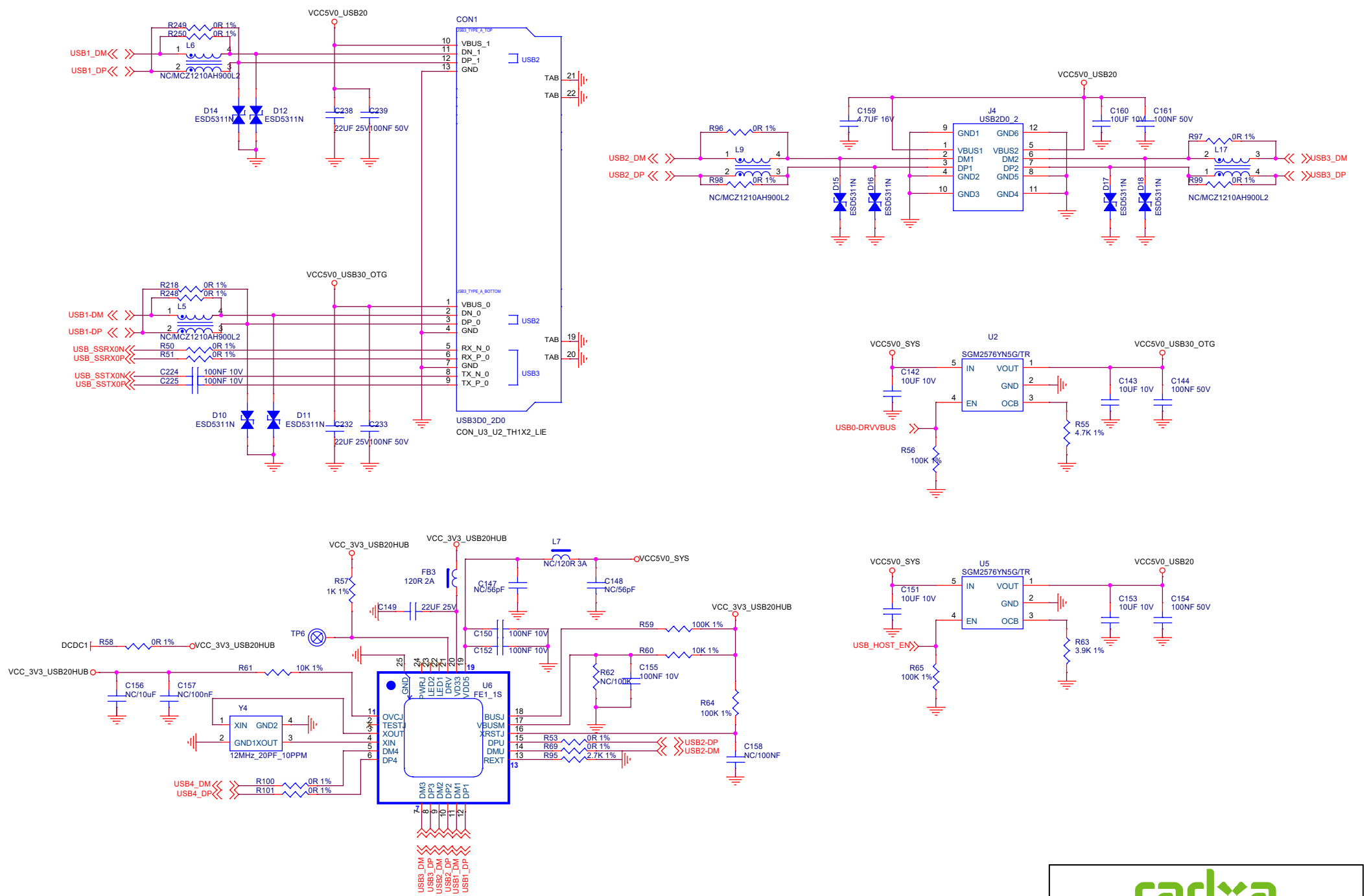



Size:	Title: <b>RS501</b>	REV
A3	Page Name: <b>14 USB20_USB30</b>	V1.10
Date: Monday, April 28, 2025	Sheet	14 of 19

# 5V POWER

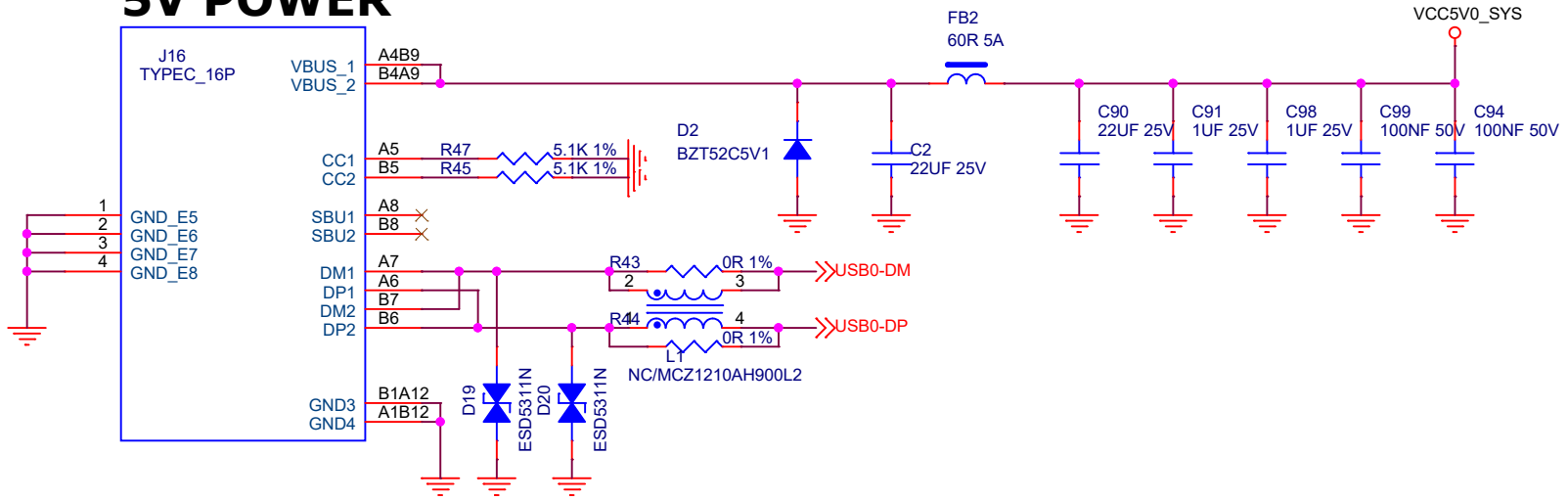

# TF CARD

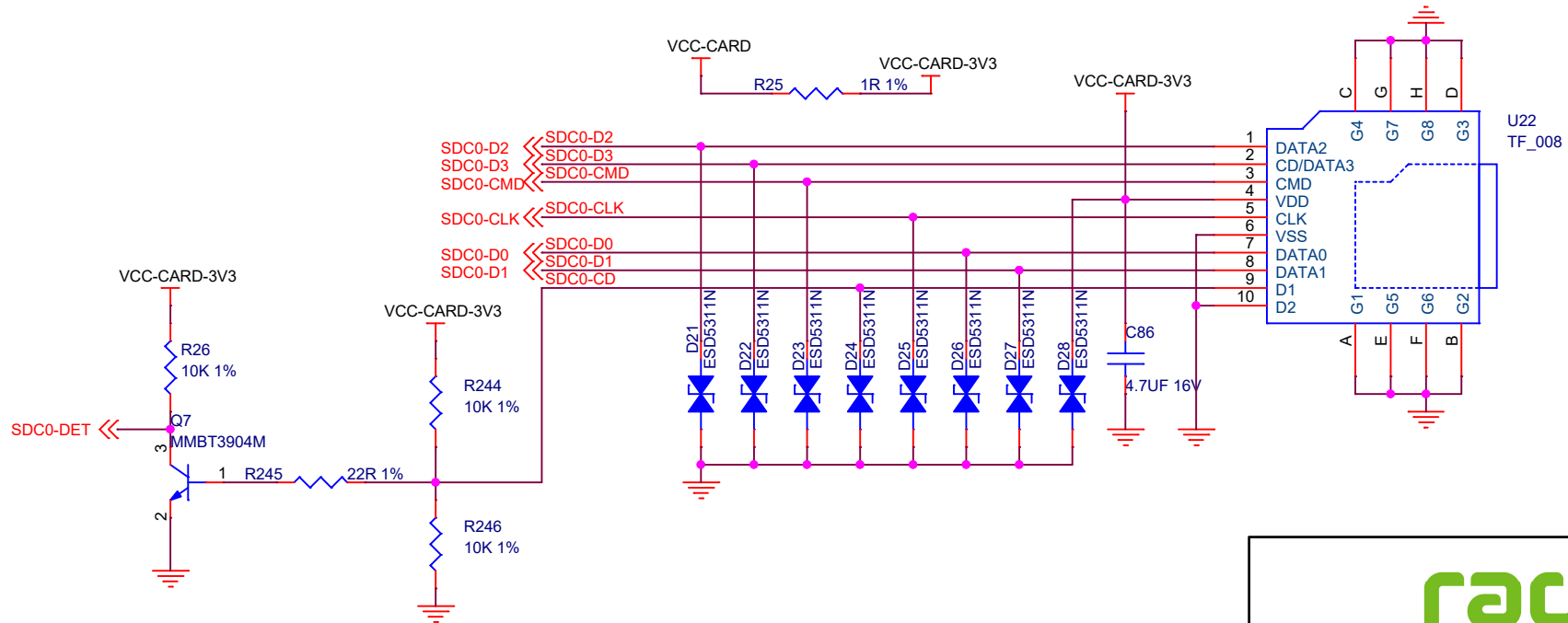

Size	Title: RS501	REV
A4	Page Name: 15 USBC0_T-CARD	V1.10
Date: Tuesday, June 10, 2025	Sheet 15 of 19	

# 40PIN\_Connector/PCIE interface

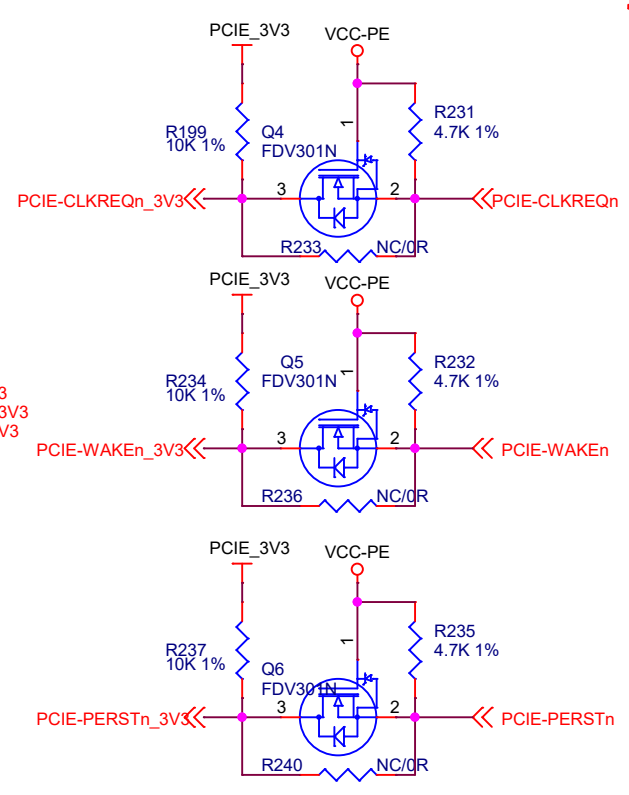
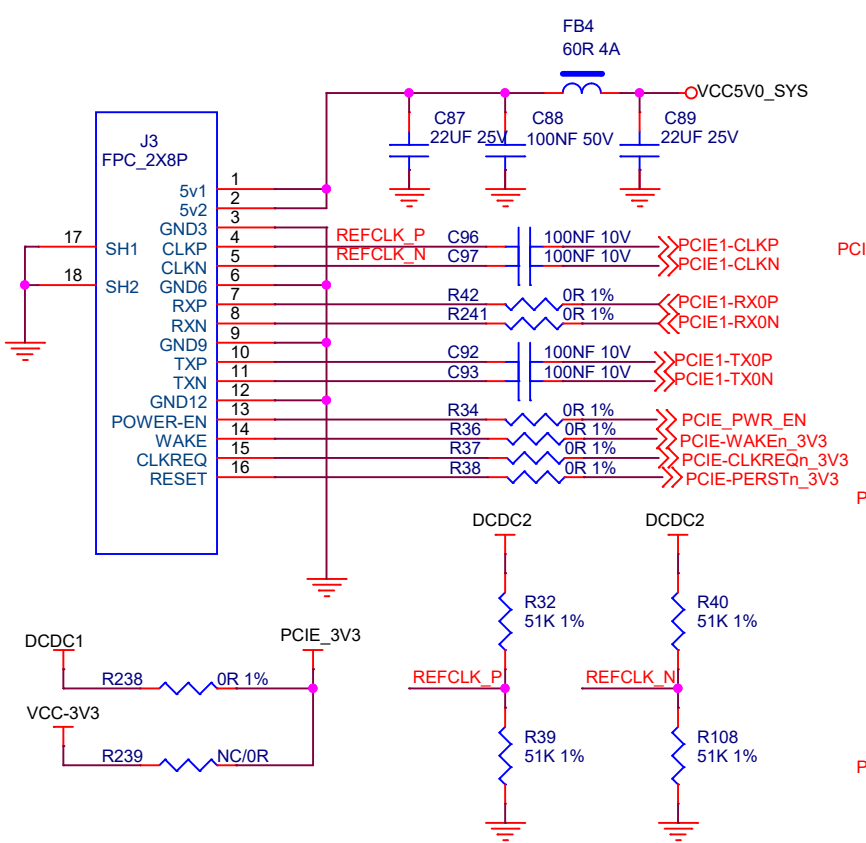
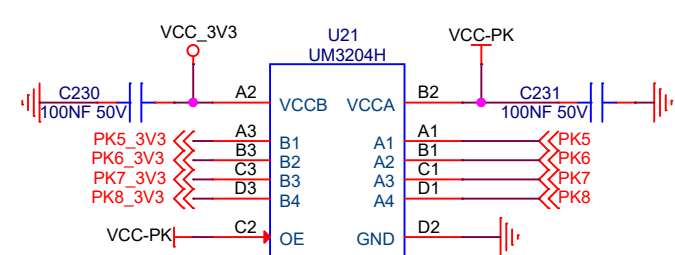
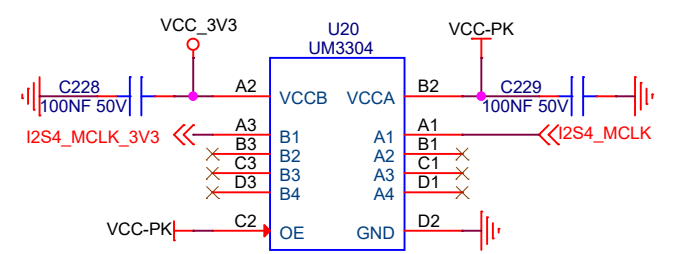
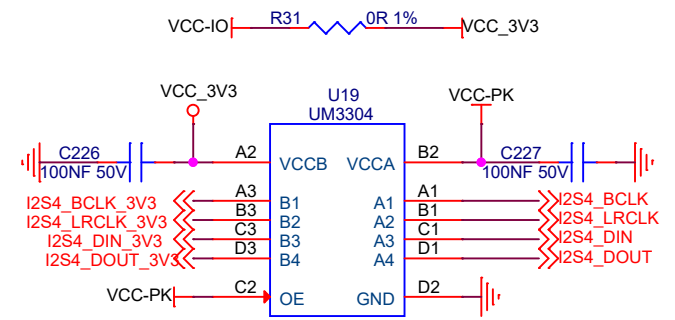
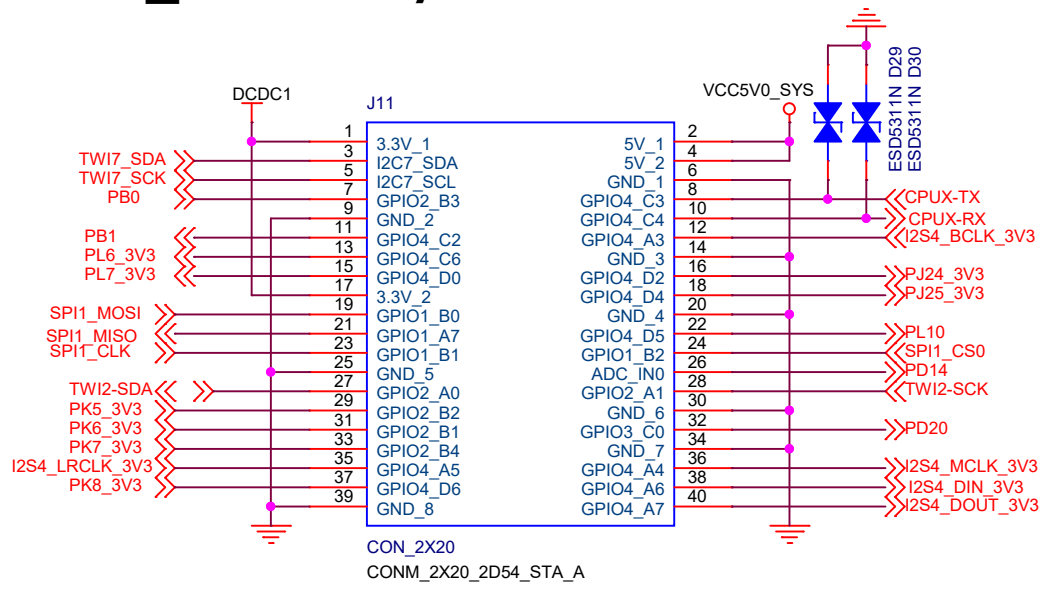

**radxa**

Size	Title: RS501	REV
A4	Page Name: 16_PCIE_40PIN_CONNECT	V1.10
Date: Monday, April 28, 2025	Sheet 16 of 19	

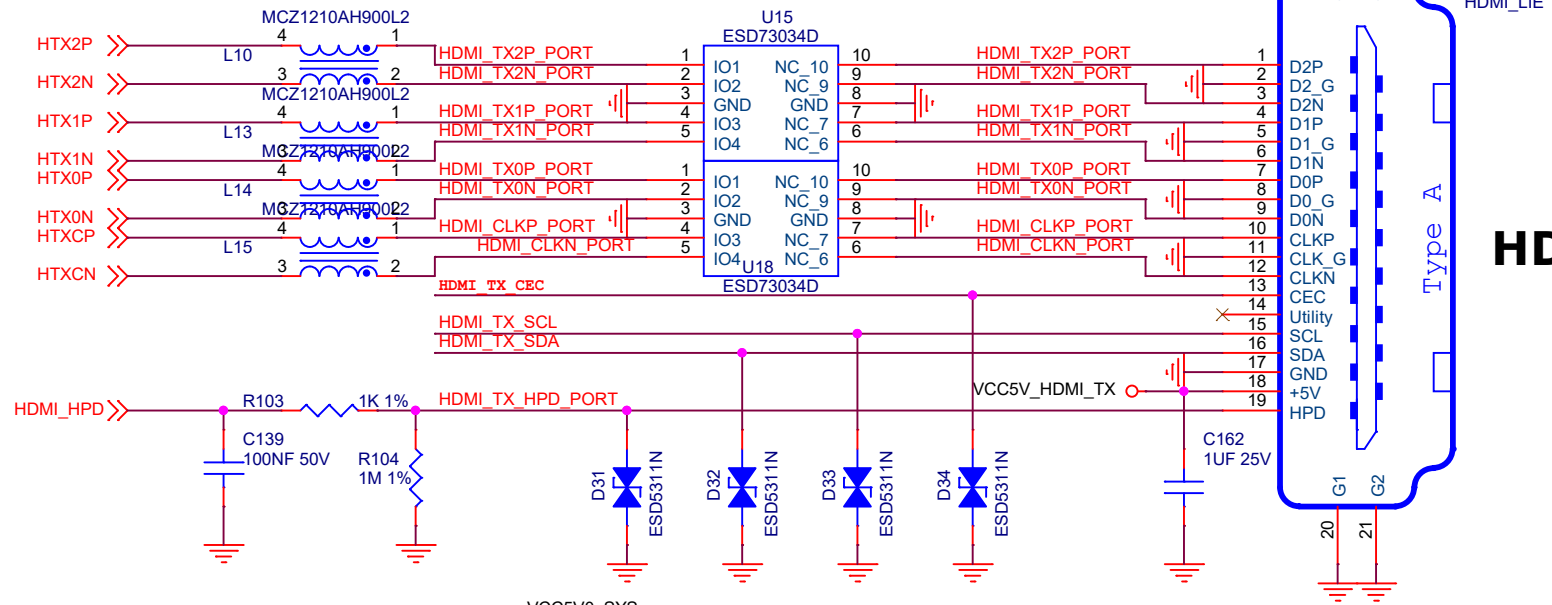

# HDMI TX

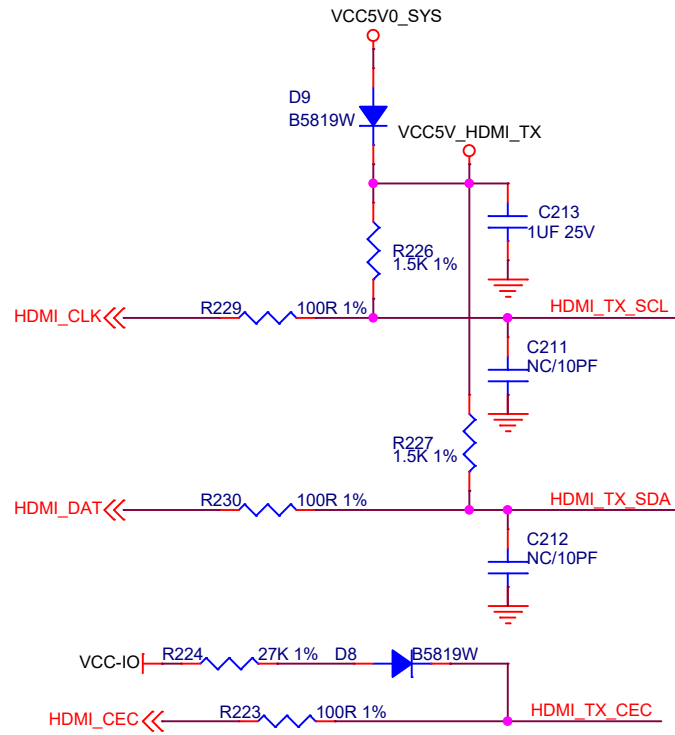

Size	Title: RS501	REV
A4	Page Name: 17.HDMI	V1.10
Date: Monday, April 28, 2025	Sheet 17 of 19	

# RGMI I

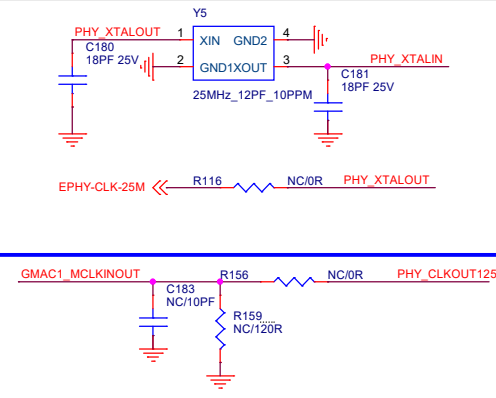
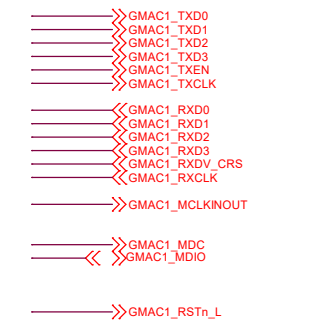

# RJ45

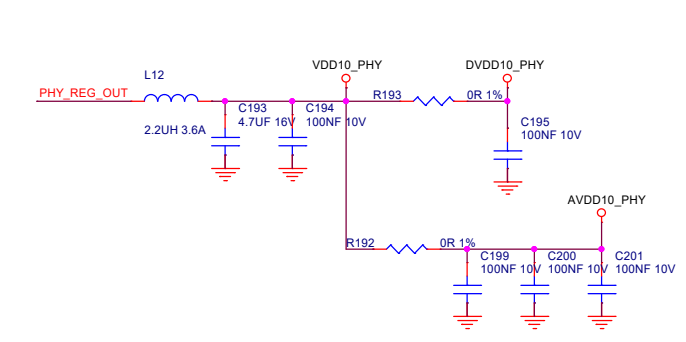
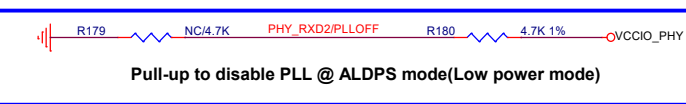
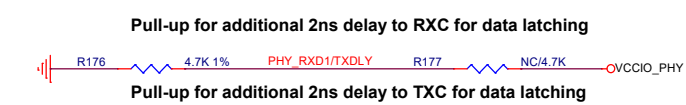
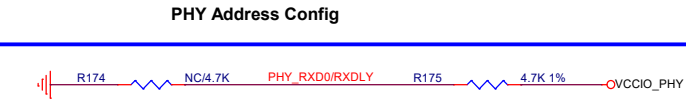
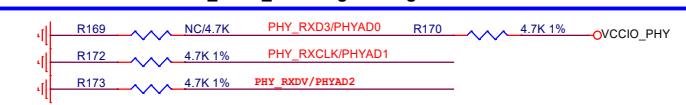
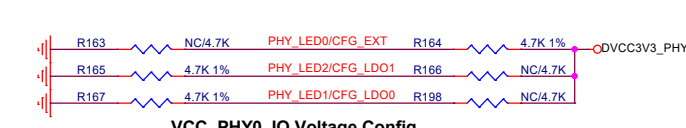
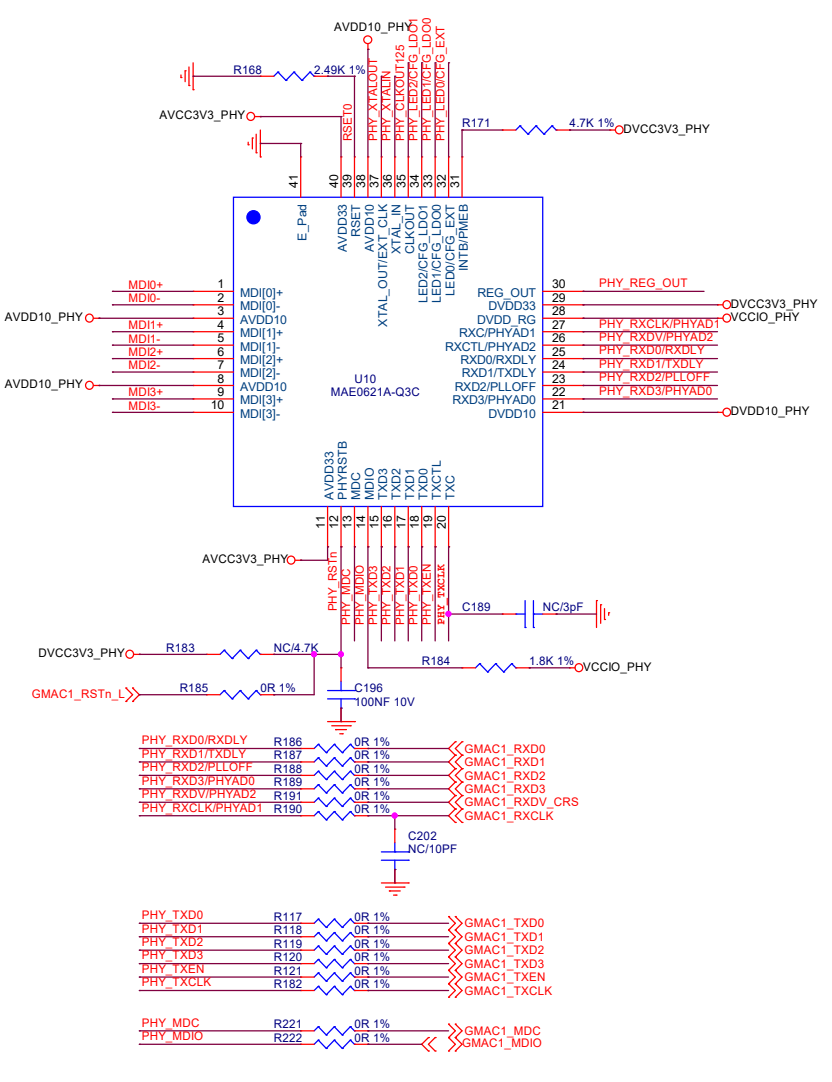
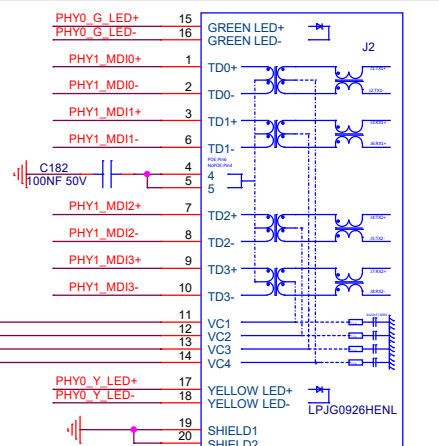
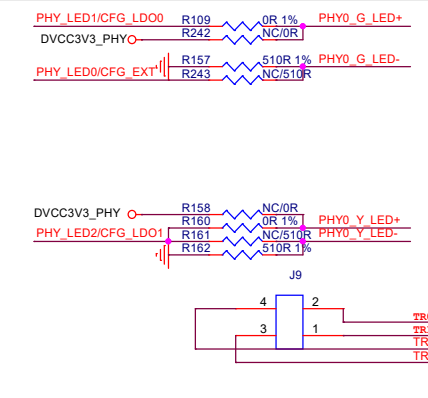
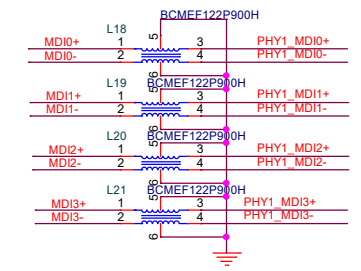

RGMI I Power Source	CFG_EXT	CFG_LDO[1:0]
External 3.3V	1'b1	2'b00
External 1.8V	1'b1	2'b10
Internal 1.8V	1'b0	2'b10

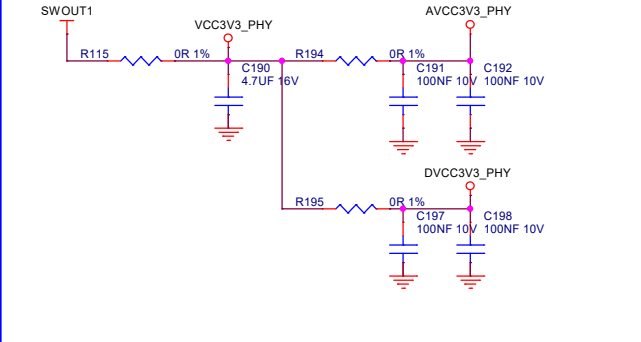
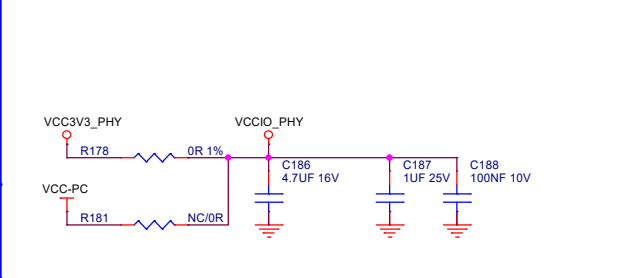
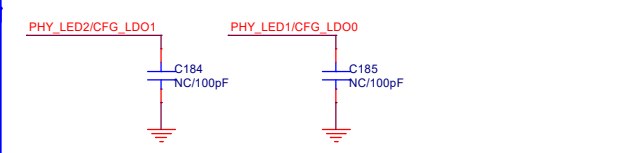

Size	Title: <b>RS501</b>	REV
A3	Page Name: <b>18 ETHERNET</b>	V1.10
Date: Thursday, July 10, 2025	Sheet 18 of 19	

# KEY

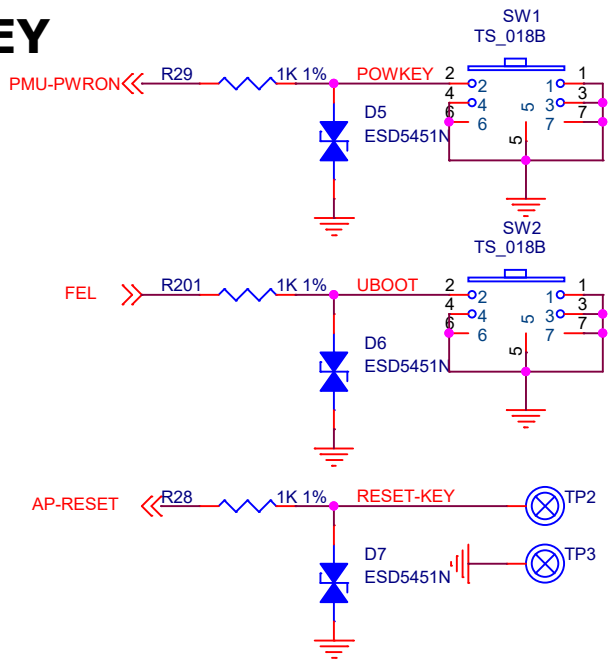

# LED

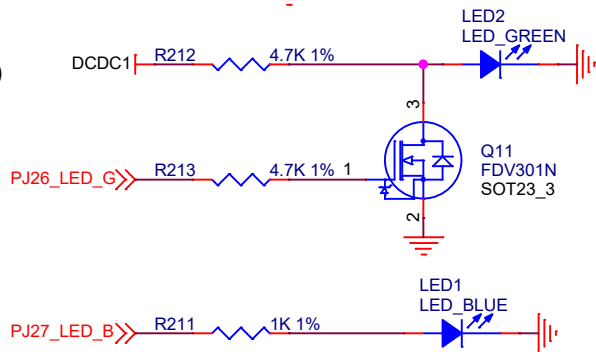

# FAN

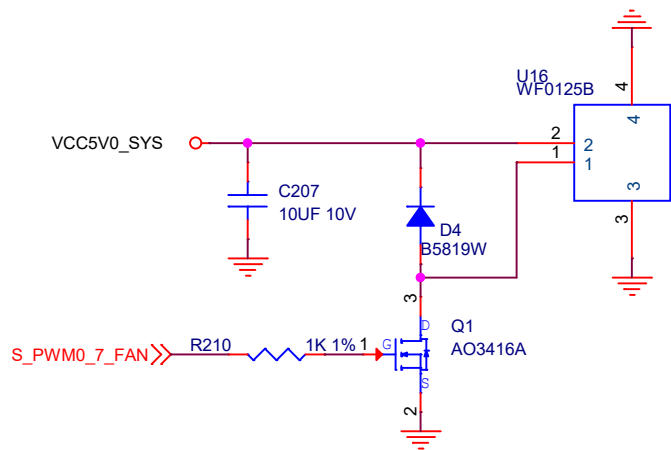

# RTC

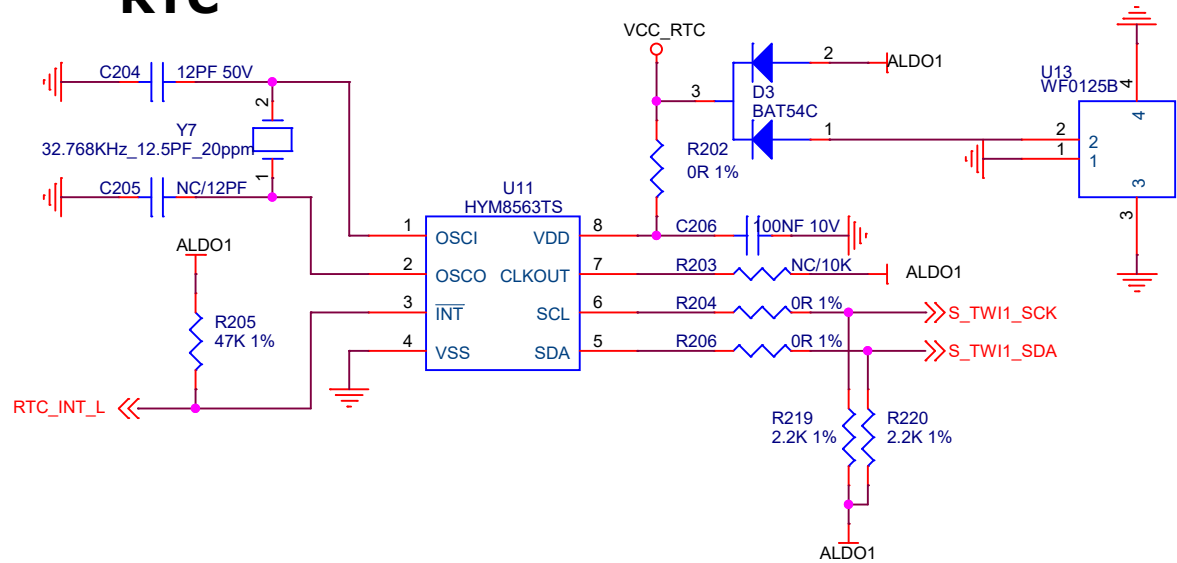

# EEPROM

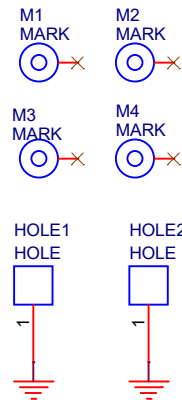
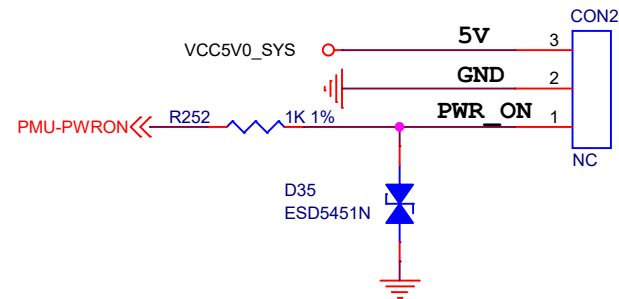
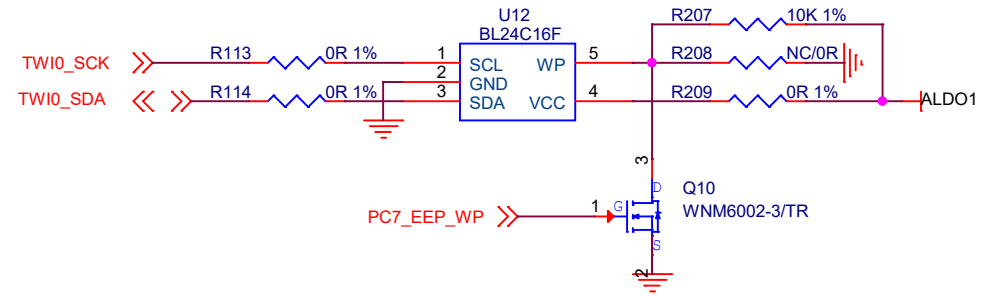

Size	Title: RS501	REV
A4	Page Name: 19 KEY_LED_RTC_FAN	V1.10
Date: Tuesday, June 10, 2025	Sheet 19 of 19	