



Radxa ROCK 4B+

schematic

V1.6

CONTENT INDEXING

- 01.Cover
- 02.Content
- 03.CONNECTOR
- 04.ES8316
- 05.PCIE NGFF/M.2
- 06.RK3399 Power
- 07.RK3399 PMU Controler
- 08.RK3399 DDR Controler
- 09.RK3399 Flash&SDMMC Controler
- 10.RK3399 USB/USIC Controler
- 11.RK3399 SARADC/Key
- 12.RK3399 DVP Interface
- 13.RK3399 Display Interface
- 14.RK3399 GPIO
- 15.RK3399 PCIE
- 16.Power-DC IN
- 17.Power-PMIC RK808-D
- 18.RTL8211E
- 19.USB OTG/HOST Port
- 20.RAM-LPDDR3(178P)
- 21.Memory-eMMC
- 22.WIFI/BTMIMO-AP6354
- 23.TF Card
- 24.HDMI Output



Size	Title: Radxa ROCK 4B+	REV
A4	Page Name: Content	1.6
Date: Wednesday, October 11, 2023	Sheet 2	of 24

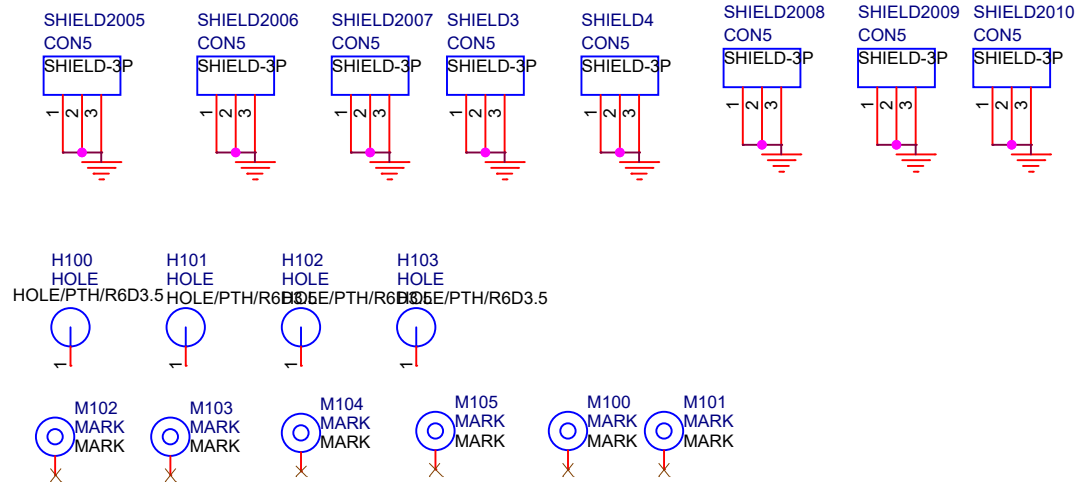
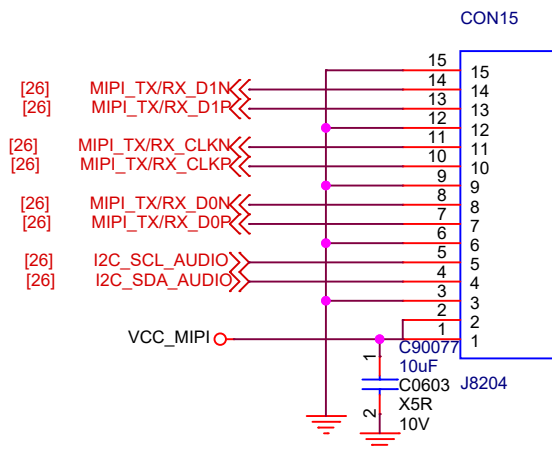
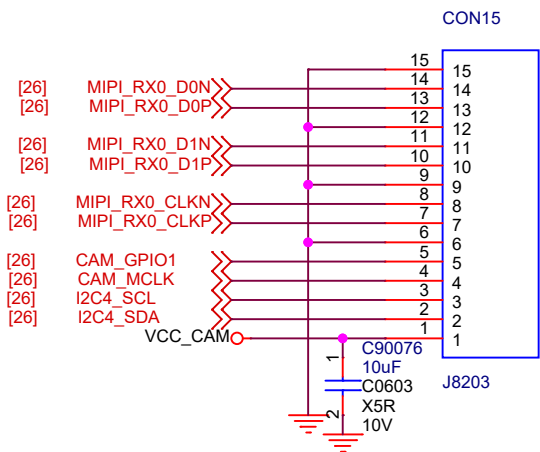
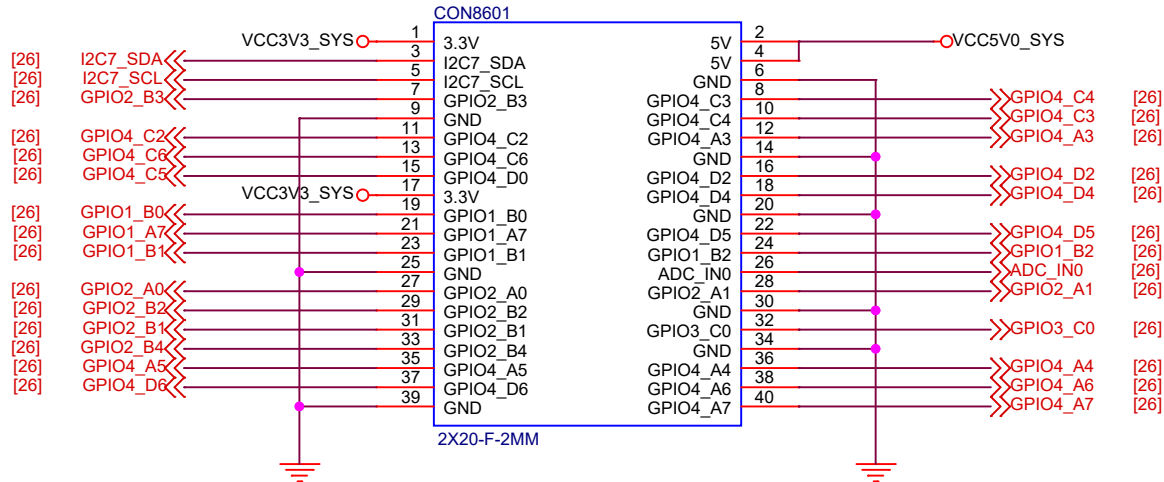
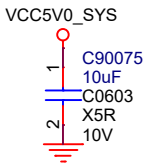
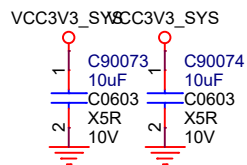

Size	Title: Radxa ROCK 4B+	REV
A4	Page Name: CONNECTOR	1.6
Date:	Wednesday, October 11, 2023	Sheet 3 of 24

I2C_SCL_AUDIO
 I2C_SDA_AUDIO
 HP_HOOK
 I2S_CLK
 I2S0_SCLK
 I2S0_LRCK_RX
 I2S0_LRCK_TX
 I2S0_SDIO
 I2S0_SDO0

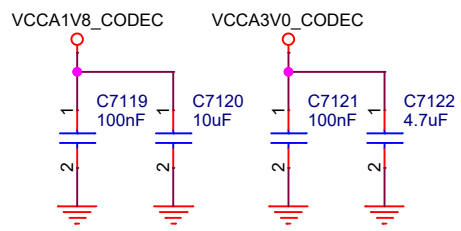
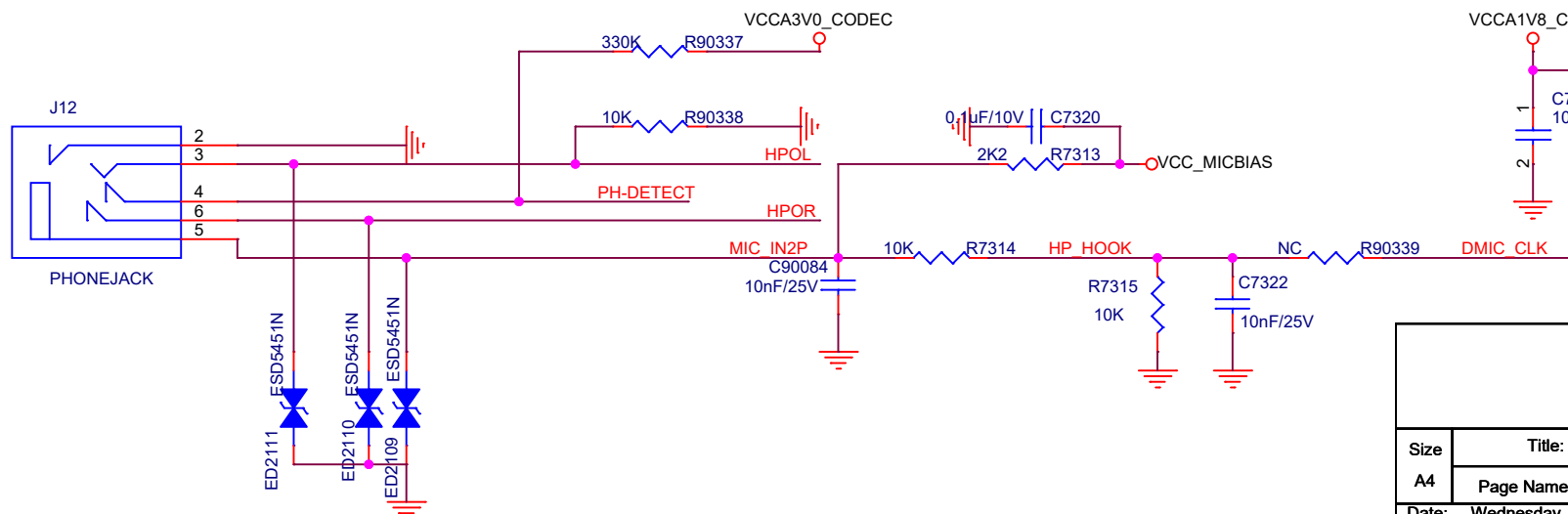
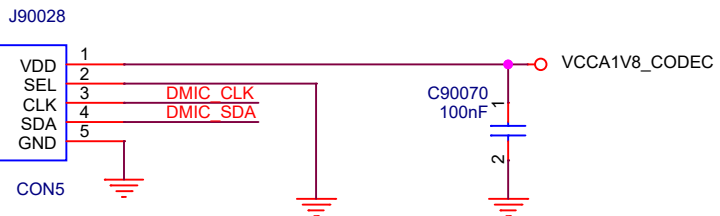
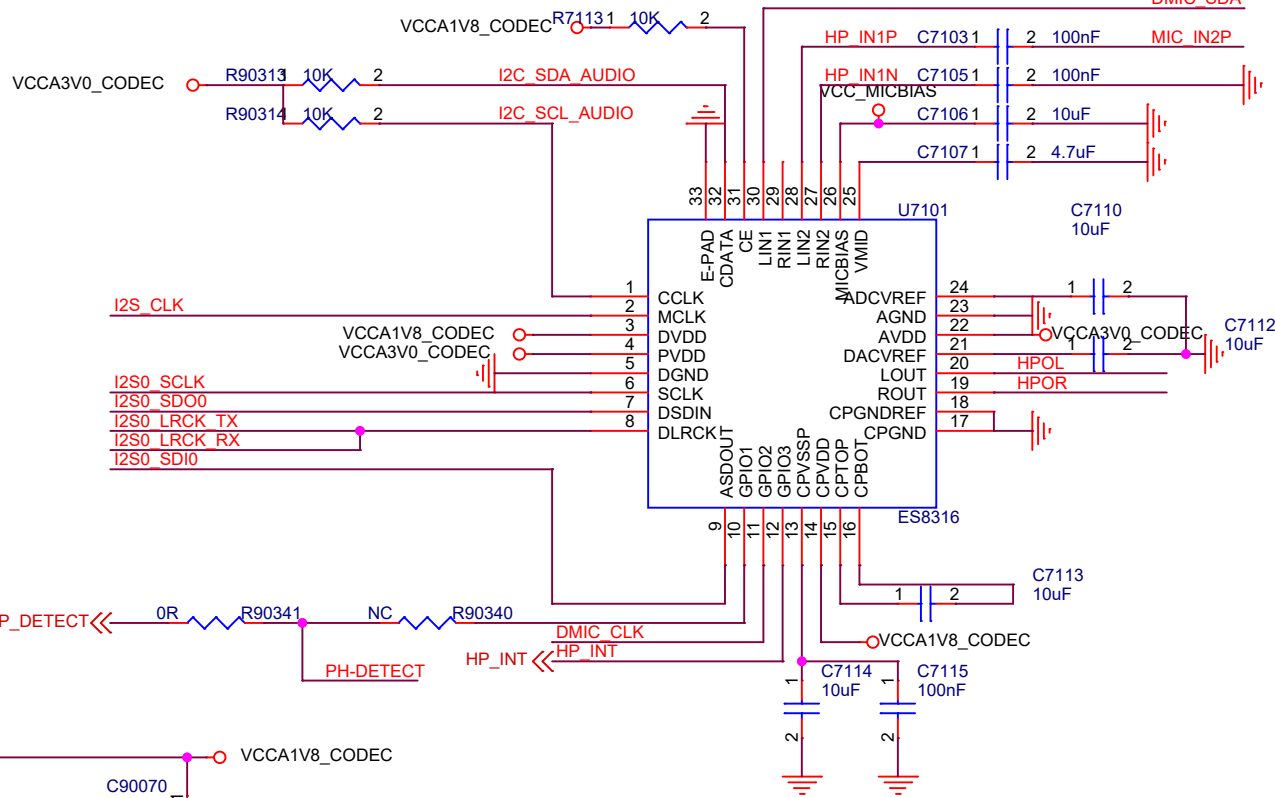

Size	Title: Radxa ROCK 4B+	REV
A4	Page Name: ES8316	1.6
Date: Wednesday, October 11, 2023	Sheet 4 of 24	

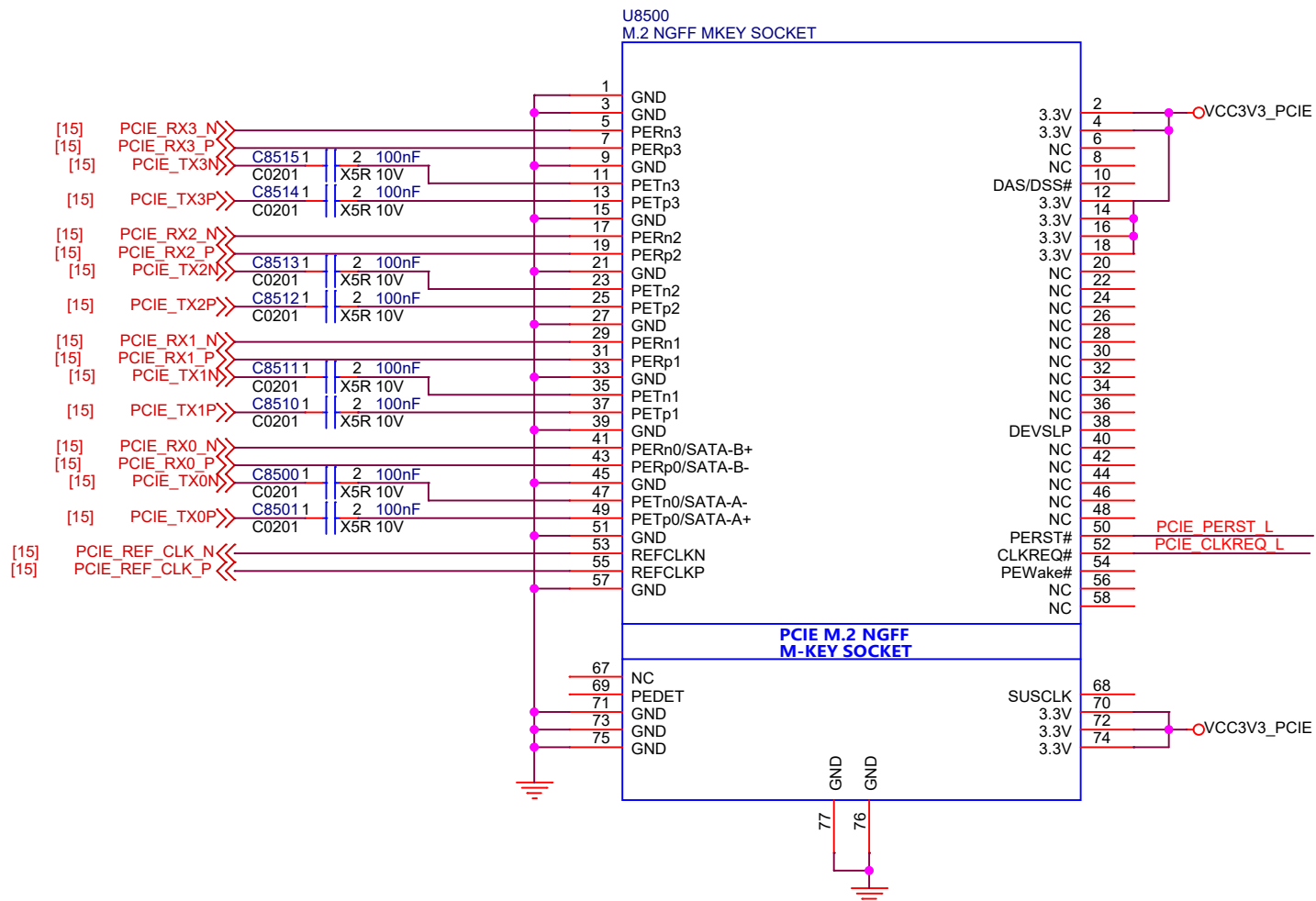

[12] PCIE_PERST_L
[14] PCIE_CLKREQ_L

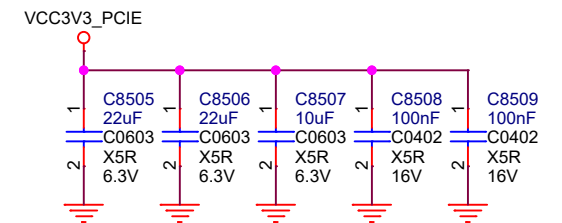
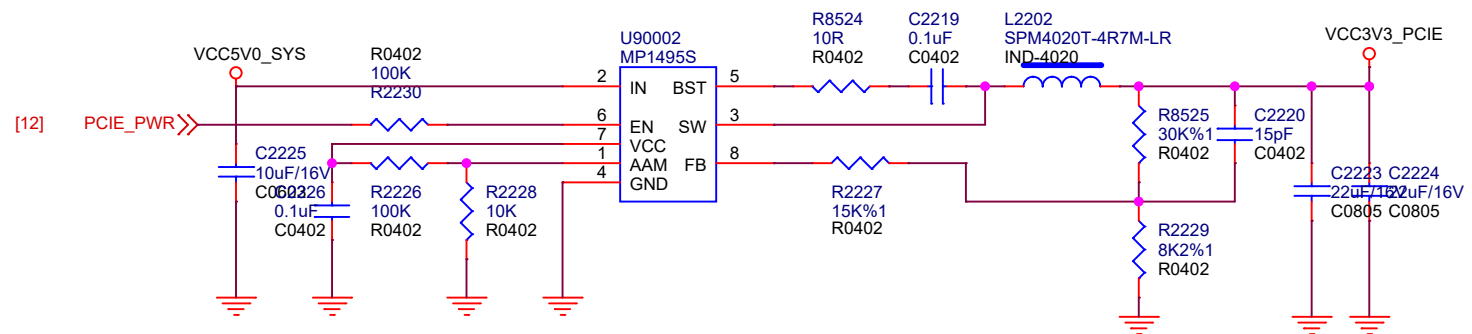



Size	Title: Radxa ROCK 4B+	REV
A4	Page Name: PCIe NGFF/M.2	1.6
Date: Wednesday, October 11, 2023		
Sheet 5 of 24		

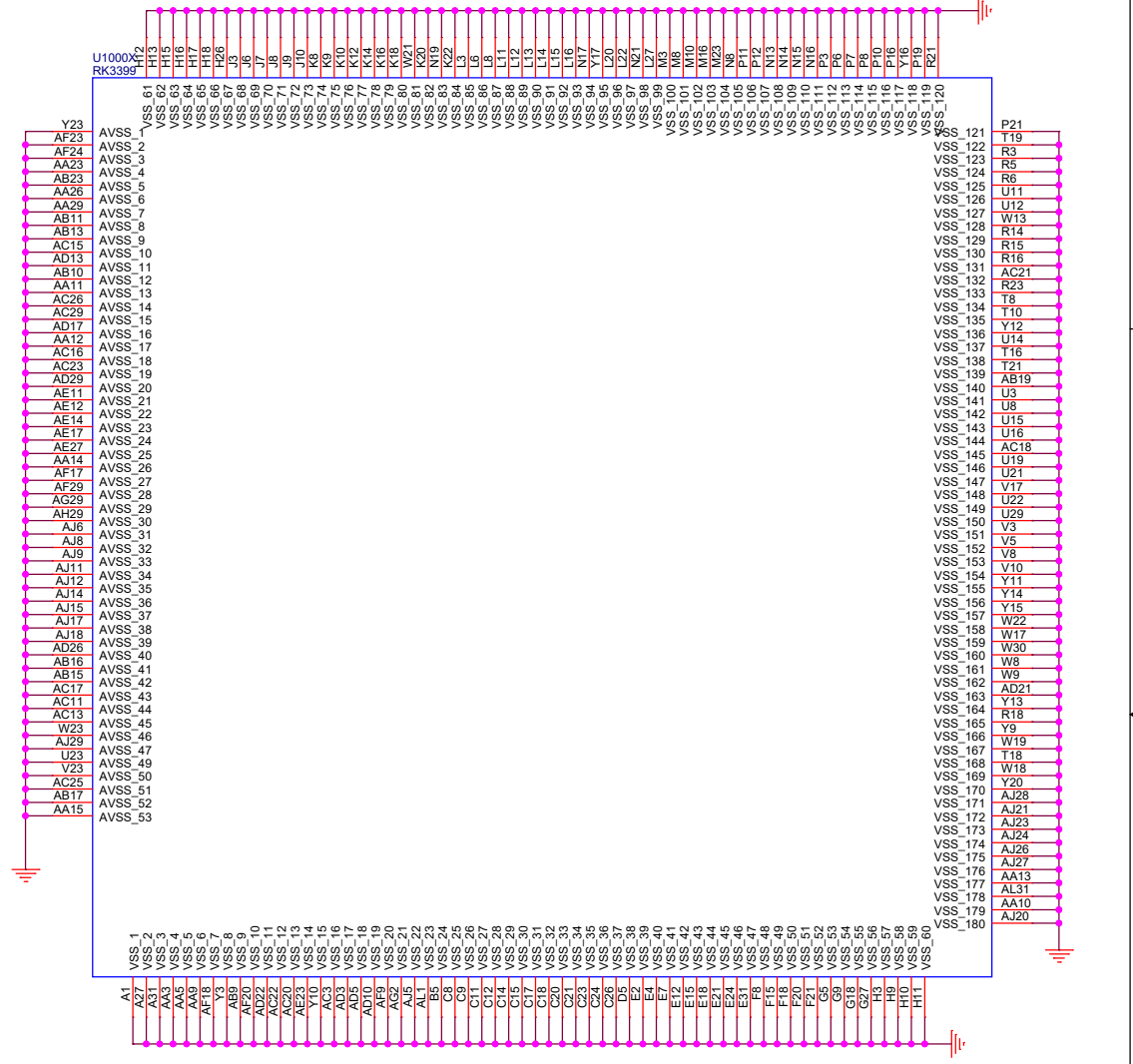
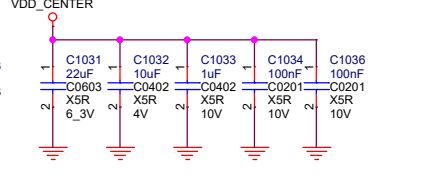
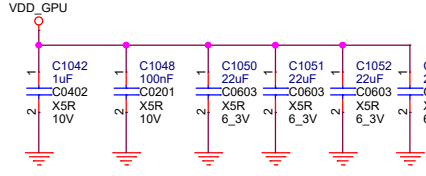
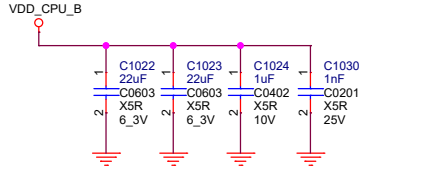
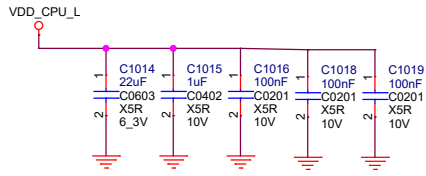
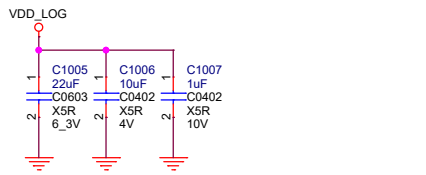
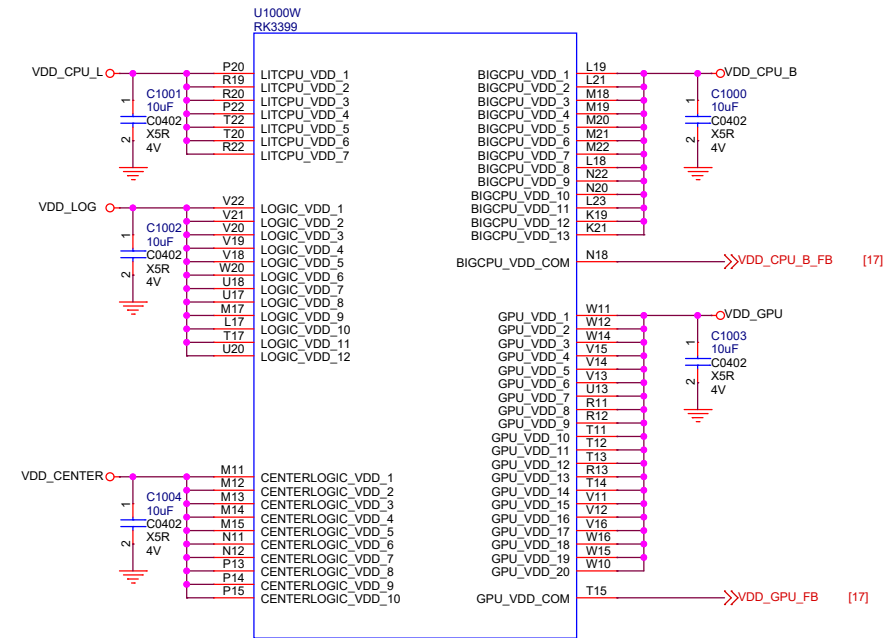

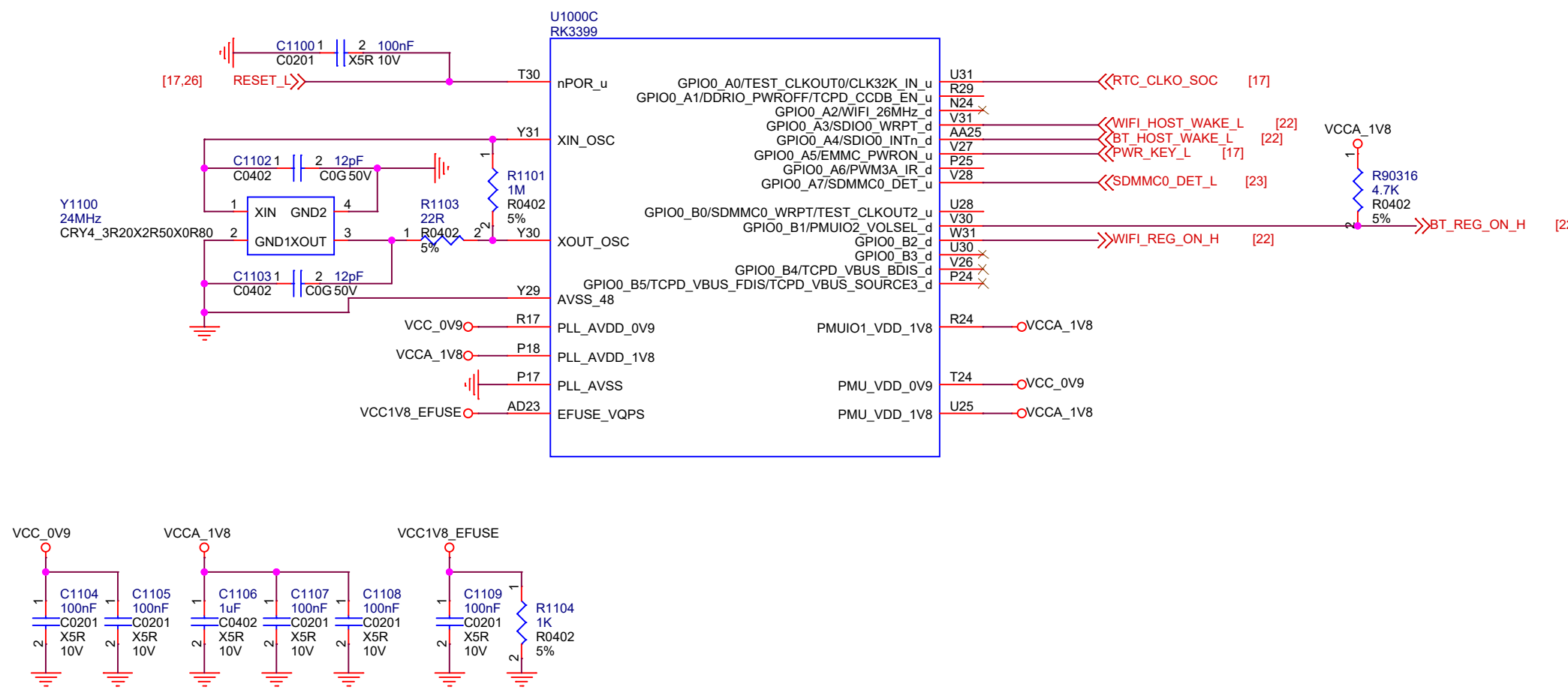

Size	Title: Radxa ROCK 4B+	REV
A4	Page Name: RK3399 PMU Controller	1.6
Date: Wednesday, October 11, 2023	Sheet 7 of 24	

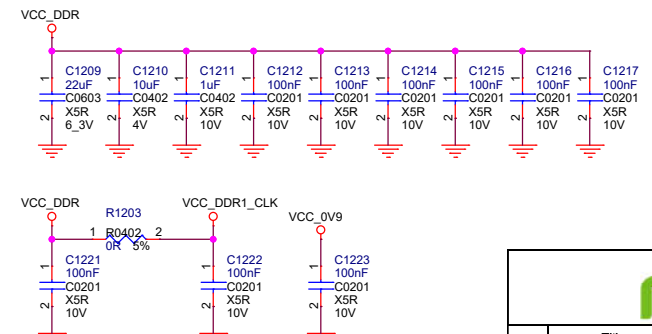
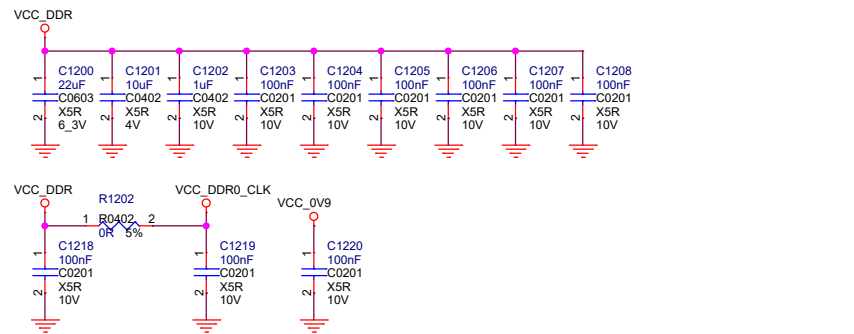
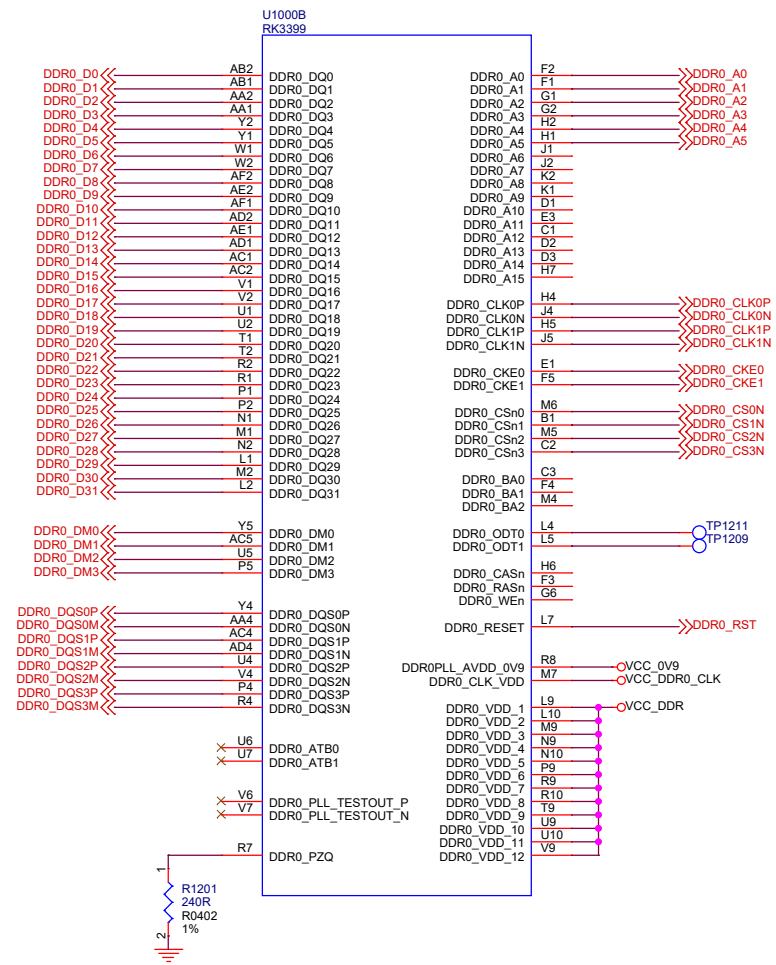
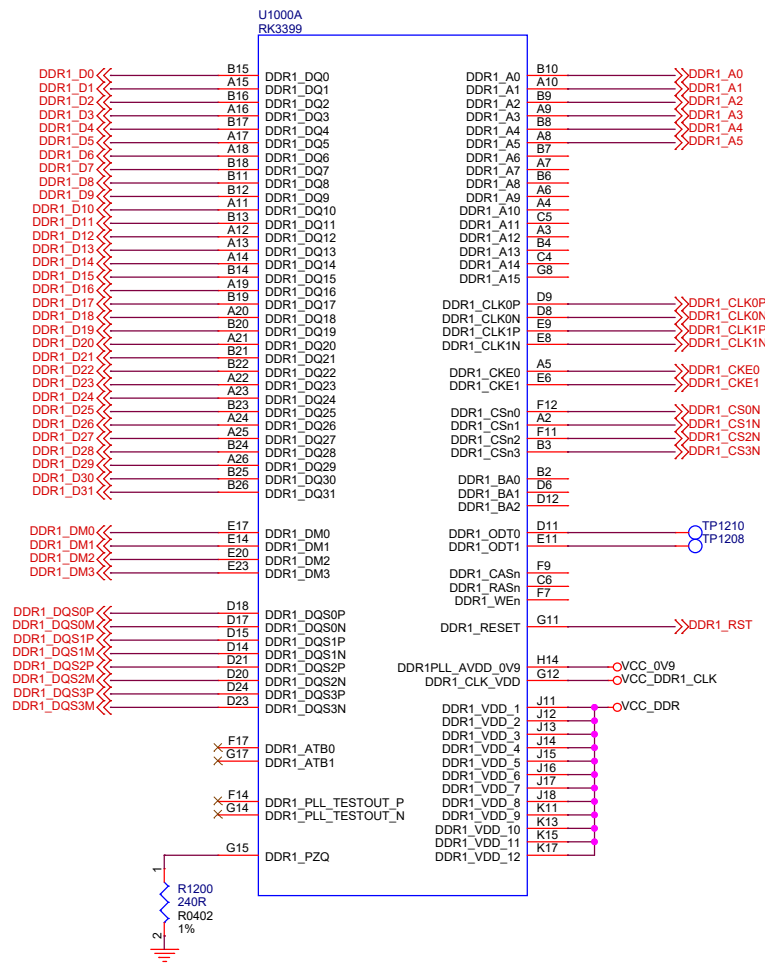

radxa

Size	Title: Radxa ROCK 4B+	REV
A3	Page Name: RK3399 DDR Controller	1.6
Date: Wednesday, October 11, 2023	Sheet 8 of 24	

U1000H
RK3399

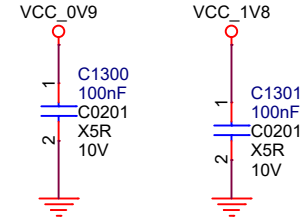
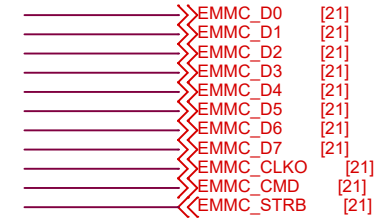
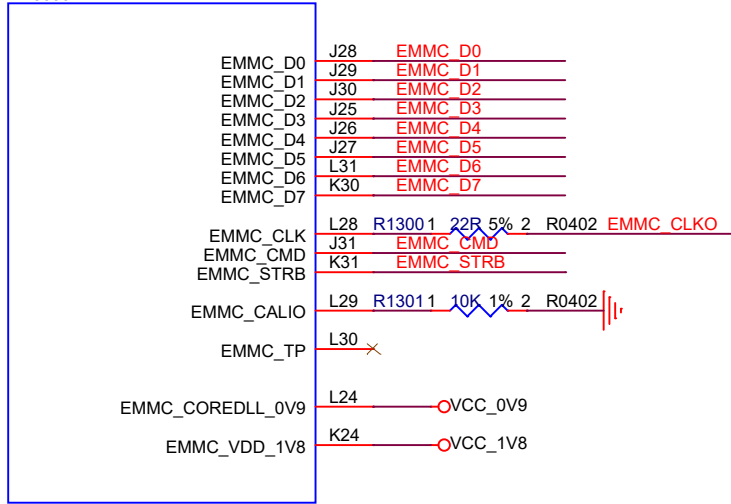

U1000F
RK3399

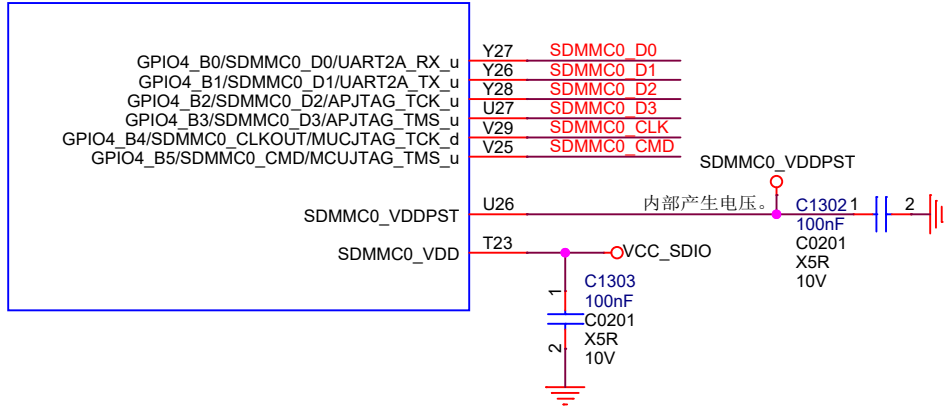

Size	Title: Radxa ROCK 4B+	REV
A4	Page Name: RK3399 Flash&SDMMC Controler	1.6
Date: Wednesday, October 11, 2023	Sheet 9 of 24	

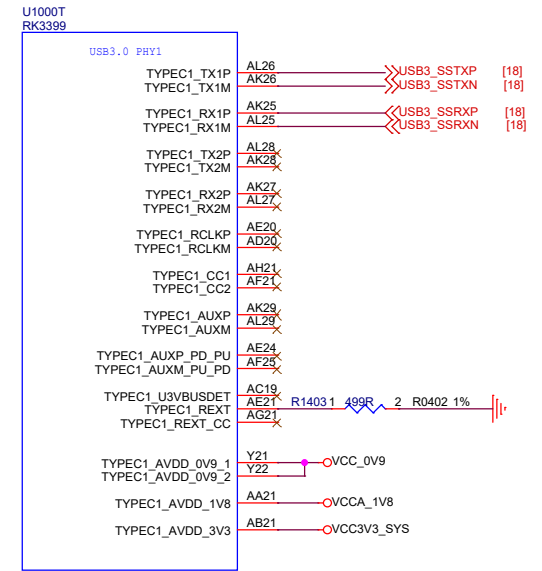
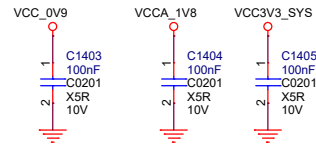
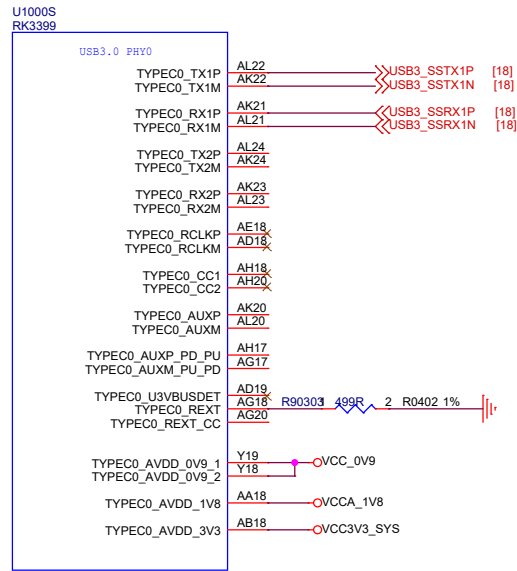
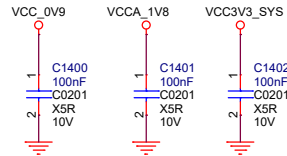
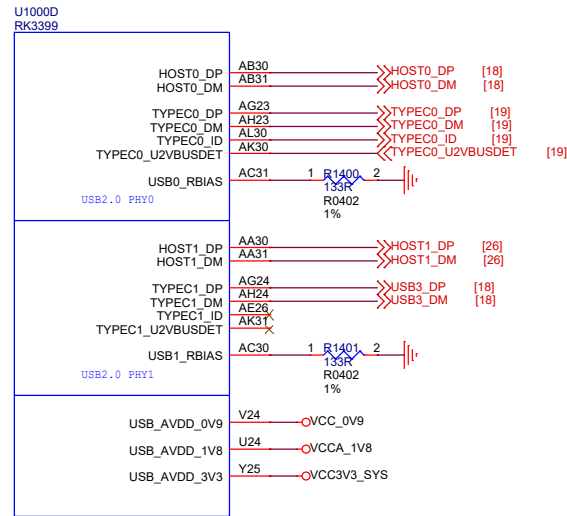
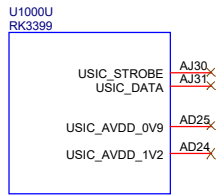

KEY BAORD

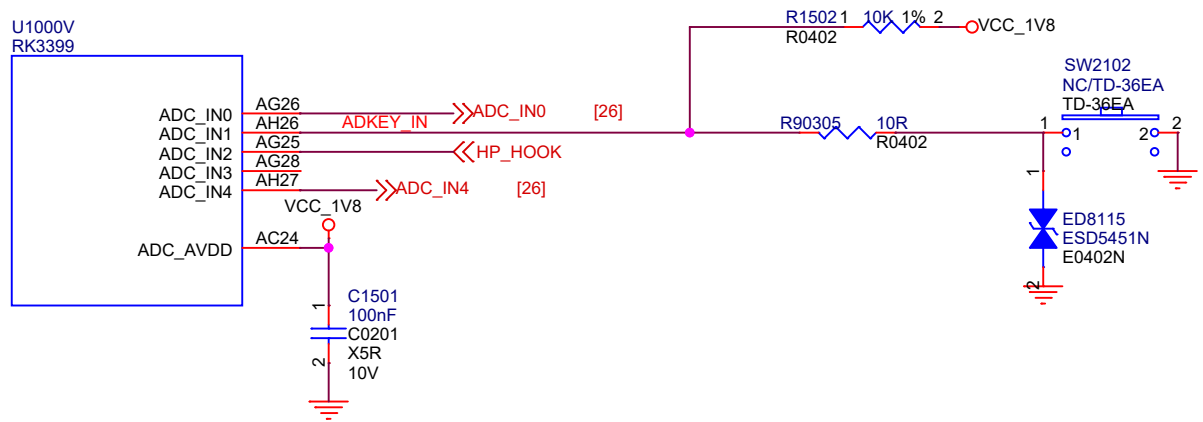

Size	Title: Radxa ROCK 4B+	REV
A4	Page Name: RK3399 SARADC/Key	1.6
Date: Wednesday, October 11, 2023	Sheet 11 of 24	

U1000L
RK3399

GPIO2_A0/VOP_D0/CIF_D0/I2C2_SDA_u G31
 GPIO2_A1/VOP_D1/CIF_D1/I2C2_SCL_u H25
 GPIO2_A2/VOP_D2/CIF_D2_d F28
 GPIO2_A3/VOP_D3/CIF_D3_d H29
 GPIO2_A4/VOP_D4/CIF_D4_d F29
 GPIO2_A5/VOP_D5/CIF_D5_d H27
 GPIO2_A6/VOP_D6/CIF_D6_d G30
 GPIO2_A7/VOP_D7/CIF_D7/I2C7_SDA_u H28
 GPIO2_B0/VOP_CLK/CIF_VSYNC/I2C7_SCL_u F30
 GPIO2_B1/SPI2_RXD/CIF_HREF/I2C6_SDA_u H24
 GPIO2_B2/SPI2_TXD/CIF_CLKIN/I2C6_SCL_u H31
 GPIO2_B3/SPI2_CLK/VOP_DEN/CIF_CLKOUTA_u F31
 GPIO2_B4/SPI2_CSn0_u

APIO2_VDDPST J24
 APPIO2_VDD K23

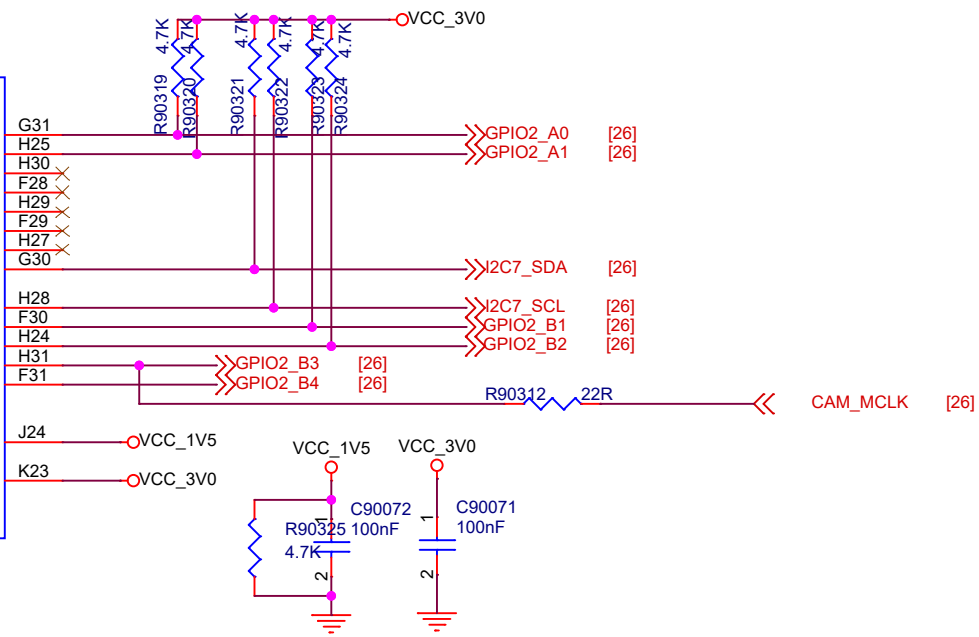

U1000R
RK3399

MIPI_RX0_D0P AK15
 MIPI_RX0_D0N AL15
 MIPI_RX0_D1P AK14
 MIPI_RX0_D1N AL14
 MIPI_RX0_CLKP AK13
 MIPI_RX0_CLKN AL13
 MIPI_RX0_D2P AK12
 MIPI_RX0_D2N AL12
 MIPI_RX0_D3P AK11
 MIPI_RX0_D3N AL11
 MIPI_RX0_REXT AF14
 MIPI_RX0_AVDD_1V8 AB14

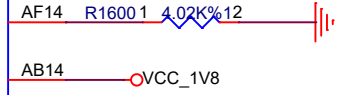

U1000P
RK3399

MIPI_TX1/RX1_D0P AK6
 MIPI_TX1/RX1_D0N AL6
 MIPI_TX1/RX1_D1P AK7
 MIPI_TX1/RX1_D1N AL7
 MIPI_TX1/RX1_CLKP AK8
 MIPI_TX1/RX1_CLKN AL8
 MIPI_TX1/RX1_D2P AK9
 MIPI_TX1/RX1_D2N AL9
 MIPI_TX1/RX1_D3P AK10
 MIPI_TX1/RX1_D3N AL10
 MIPI_TX1/RX1_REXT AF11
 MIPI_TX1/RX1_AVDD_1V8 AC10

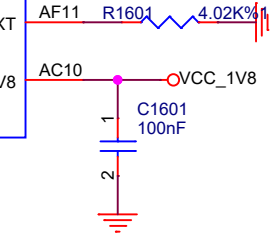

Dual
MIPI
Right



Size	Title: Radxa ROCK 4B+	REV
A4	Page Name: RK3399 DVP Interface	1.6
Date: Wednesday, October 11, 2023	Sheet 12 of 24	

U1000N
RK3399

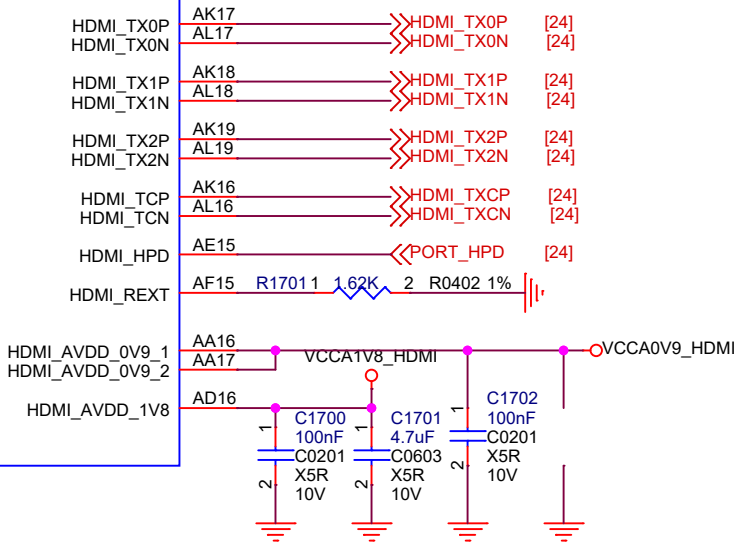

U1000M
RK3399

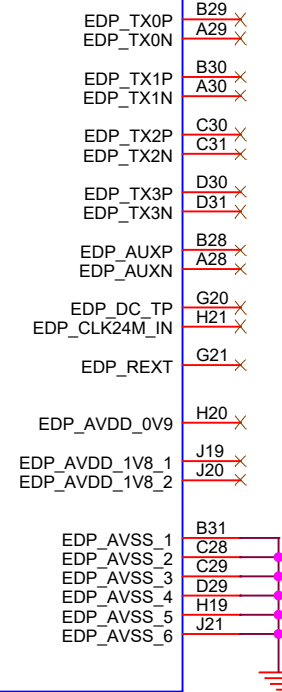

U1000Q
RK3399

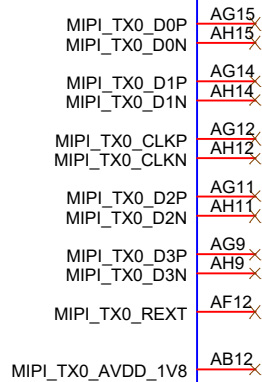

Size	Title: Radxa ROCK 4B+	REV
A4	Page Name: RK3399 Display Interface	1.6
Date: Wednesday, October 11, 2023	Sheet 13 of 24	

U10000
RK3399

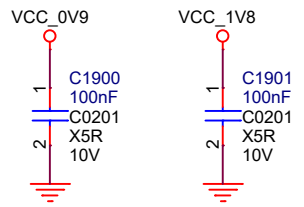
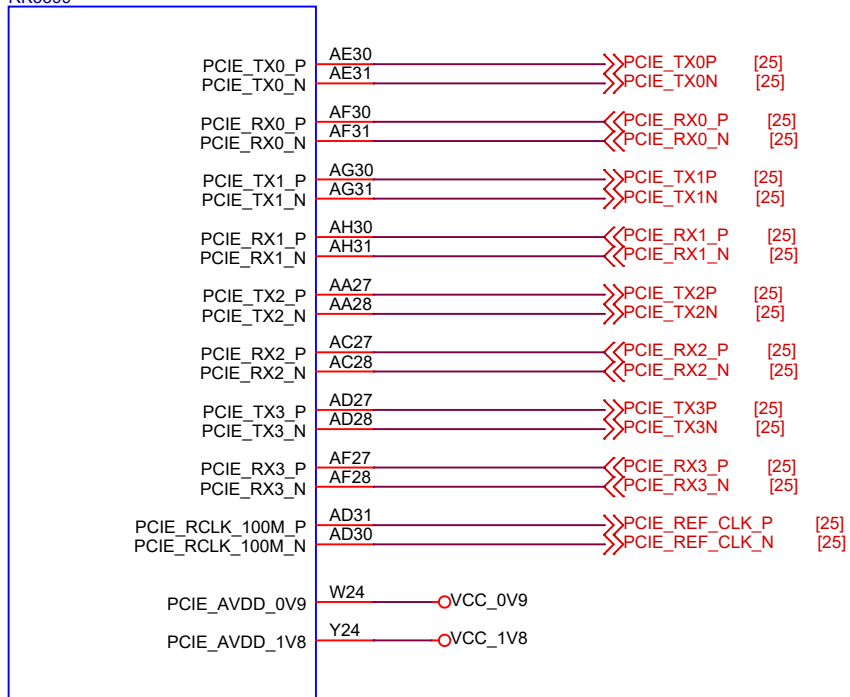

PMIC

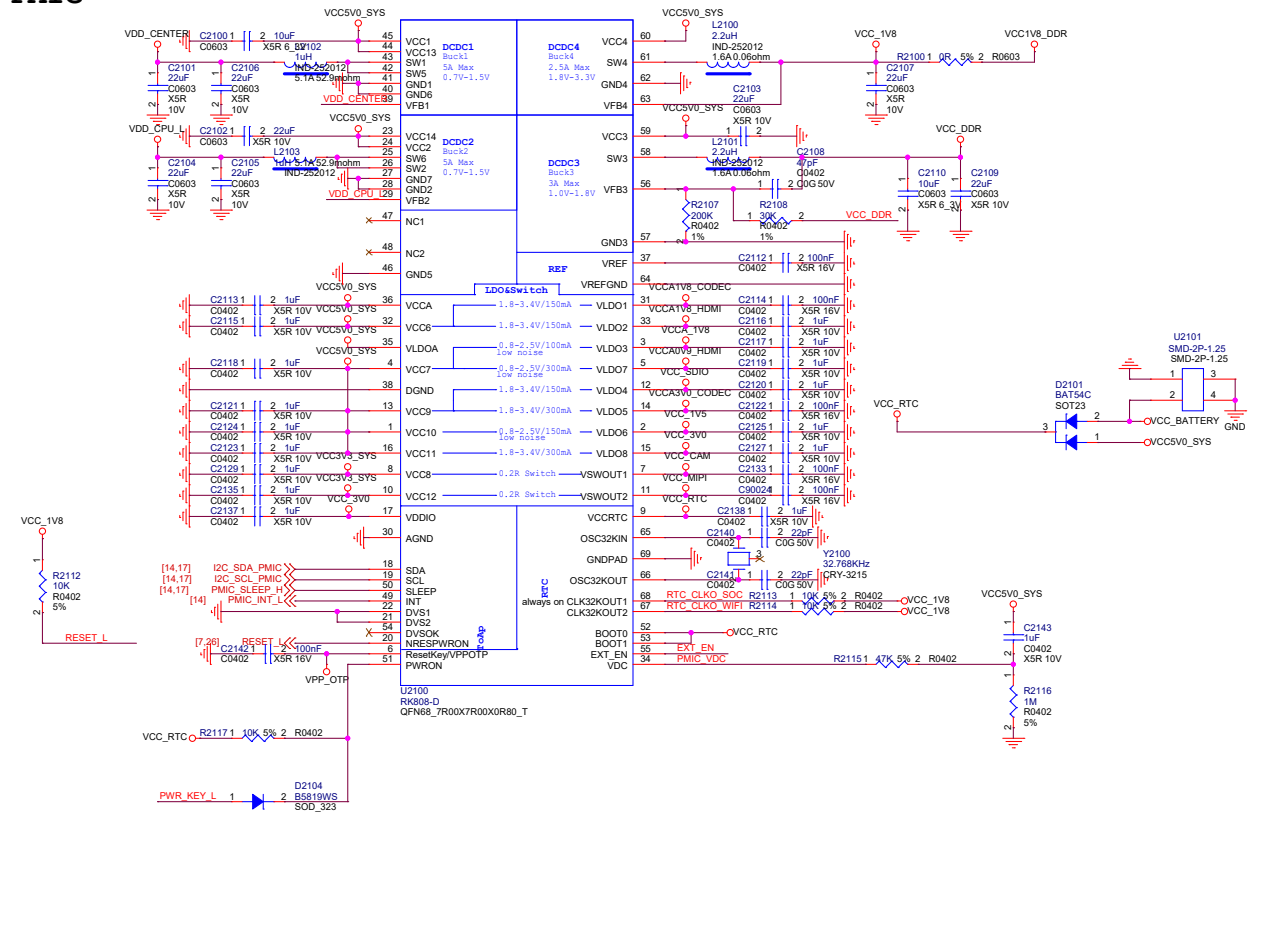

- RTN_CLKO_SOC [7]
- RTN_CLKO_WIFI [28]
- I2C_SCL_PMIC [14,17]
- I2C_SDA_PMIC [14,17]
- PMIC_SLEEP_H [14,17]
- PWR_KEY_L [7]

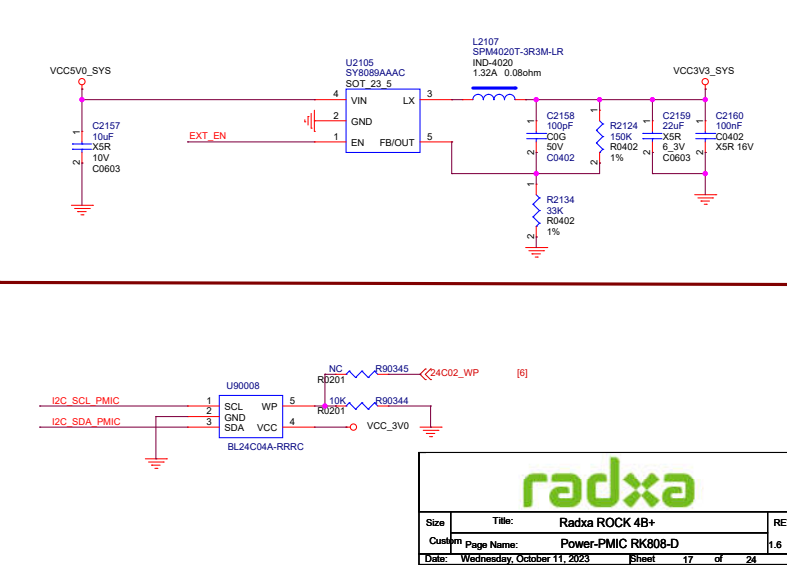
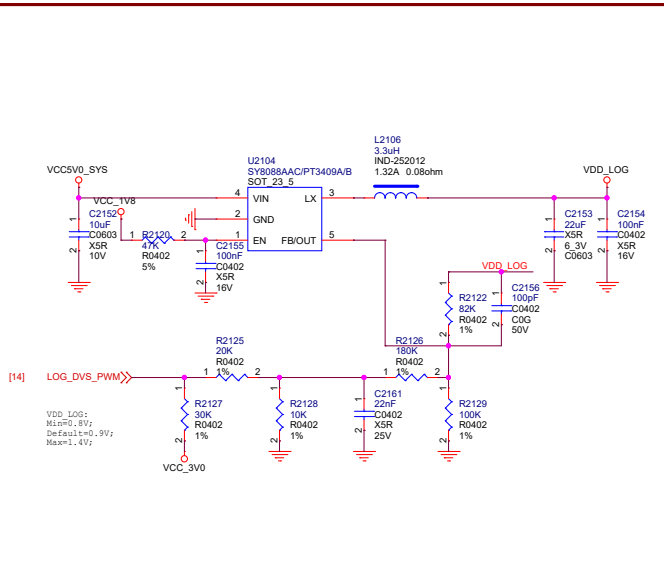
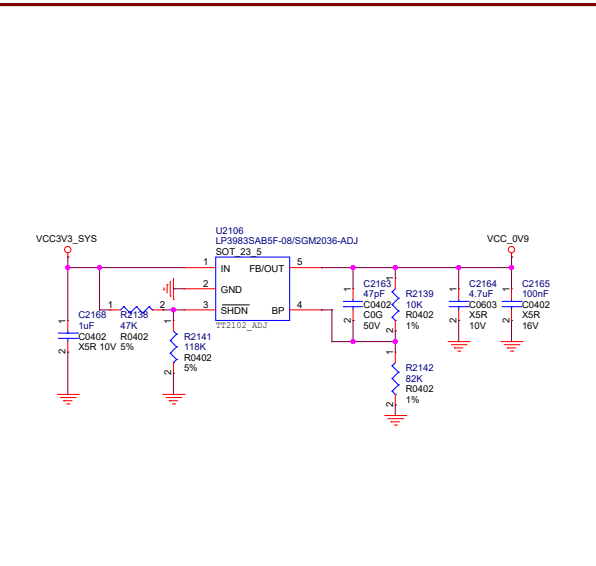
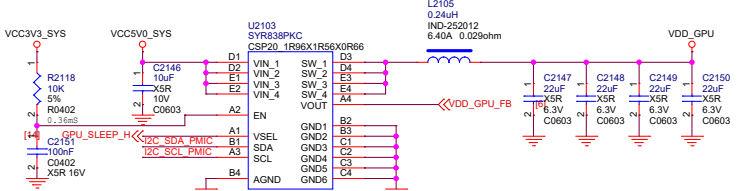
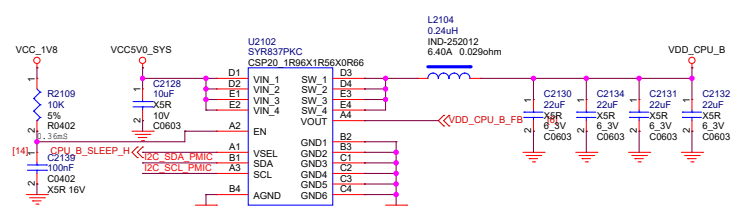
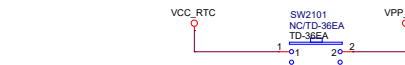

radxa

Size	Title: Radxa ROCK 4B+	REV	
Customer	Page Name: Power-PMIC RK808-D		1.8
Date: Wednesday, October 11, 2023 17 of 24			

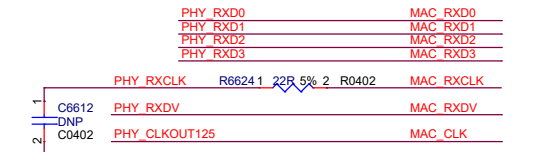
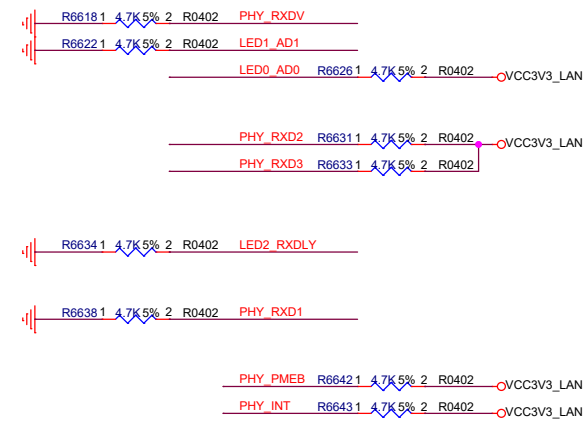
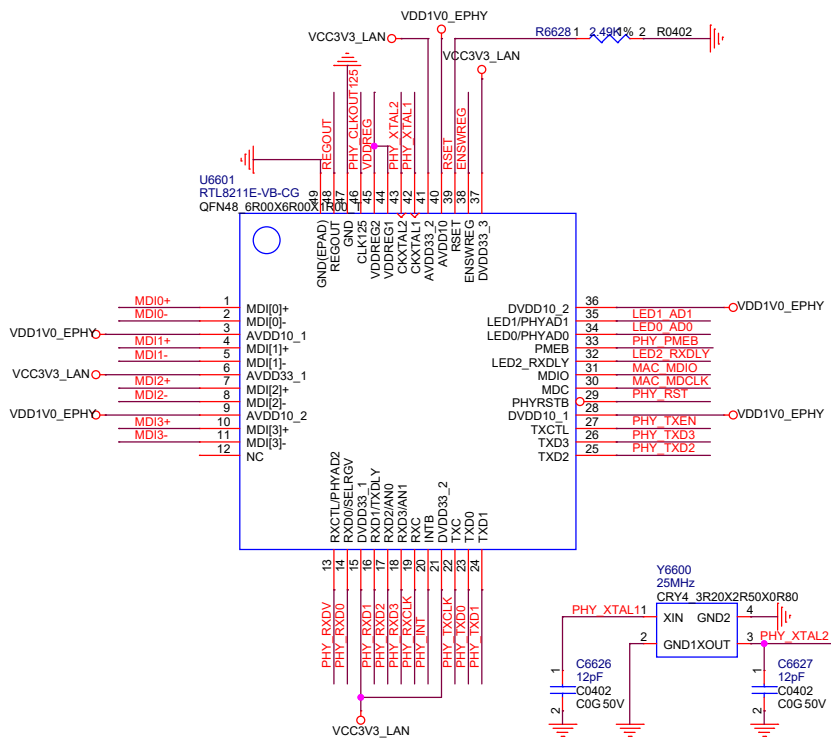
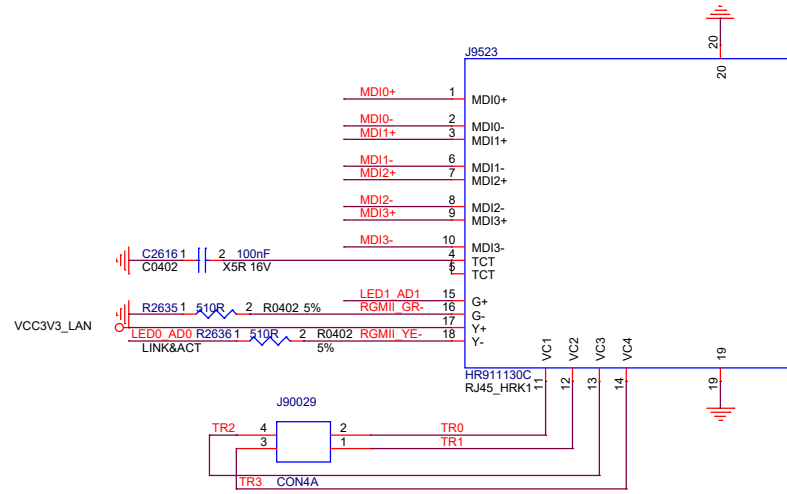
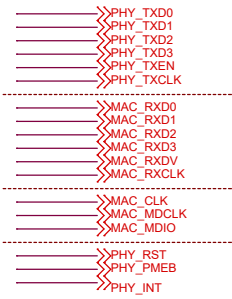

Close to PHY

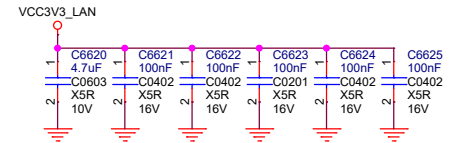
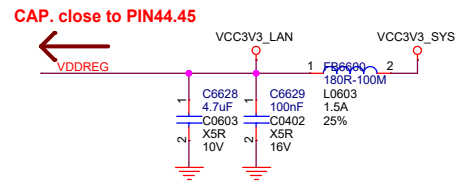
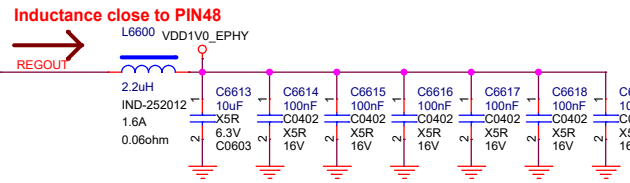
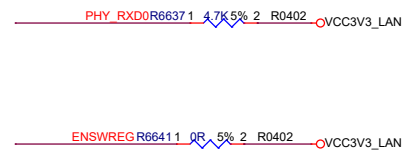

radxa

Size	Title: Radxa ROCK 4B+	REV
A3	Page Name: RTL8211E	1.6
Date: Wednesday, October 11, 2023	Sheet 18 of 24	

USB3.0 OTG port

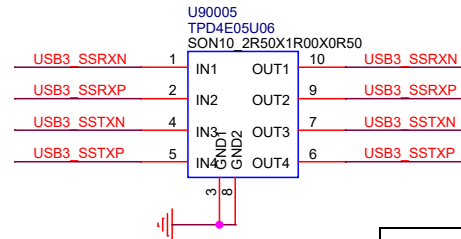
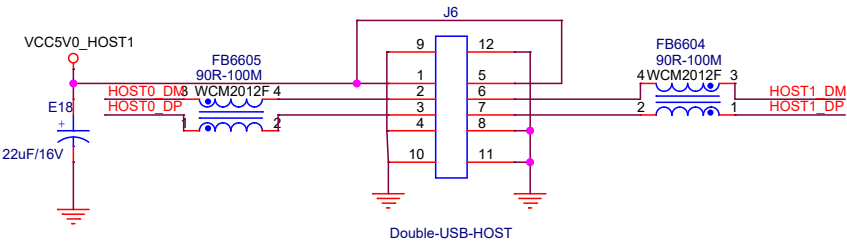
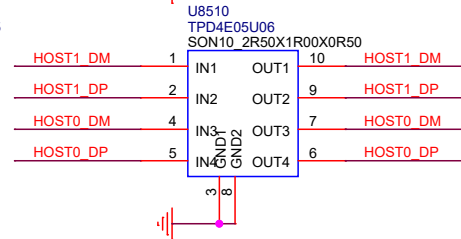
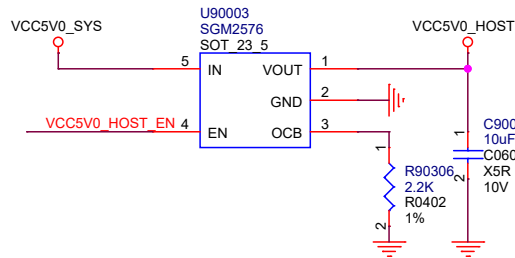
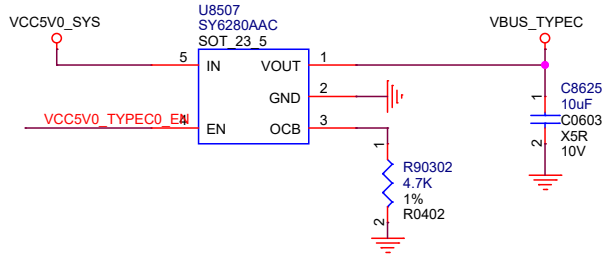
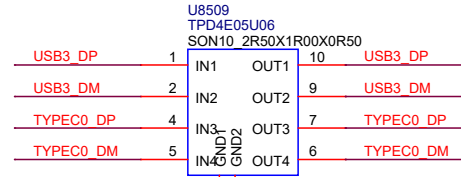
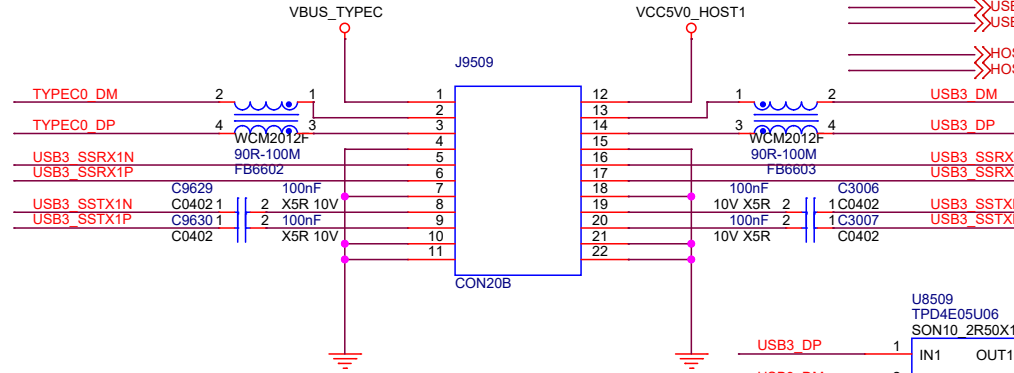
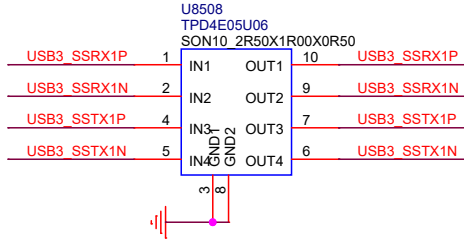
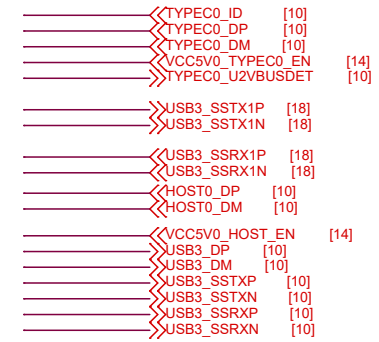
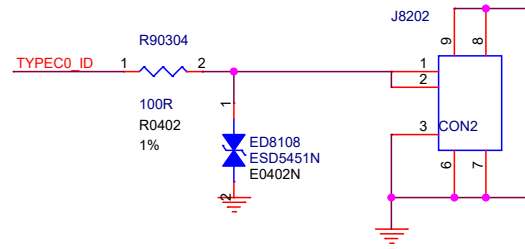
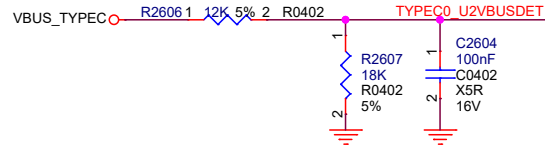

Size	Title: Radxa ROCK 4B+	REV
Custom	Page Name: USB OTG/HOST Port	1.6
Date: Wednesday, October 11, 2023	Sheet 19 of 24	

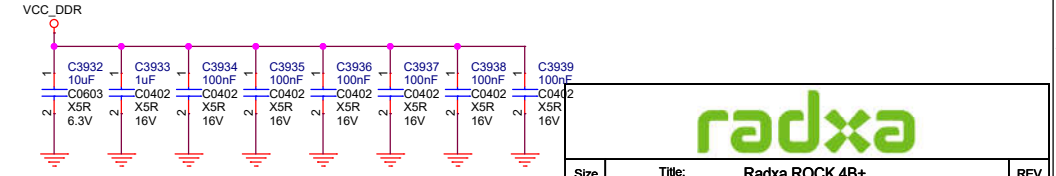
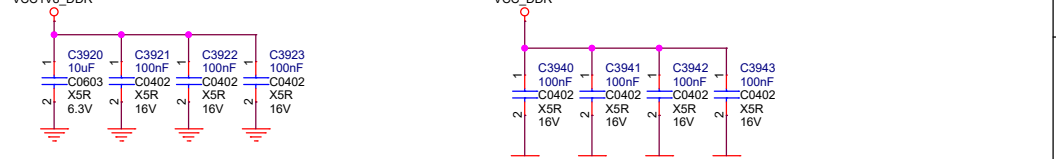
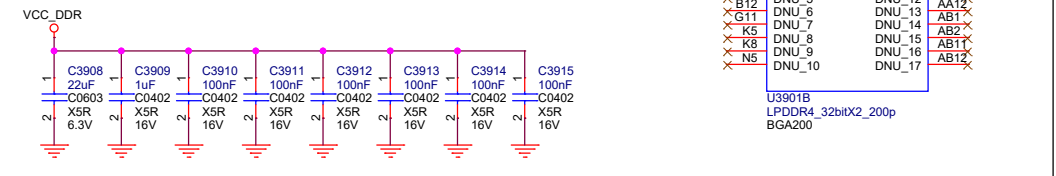
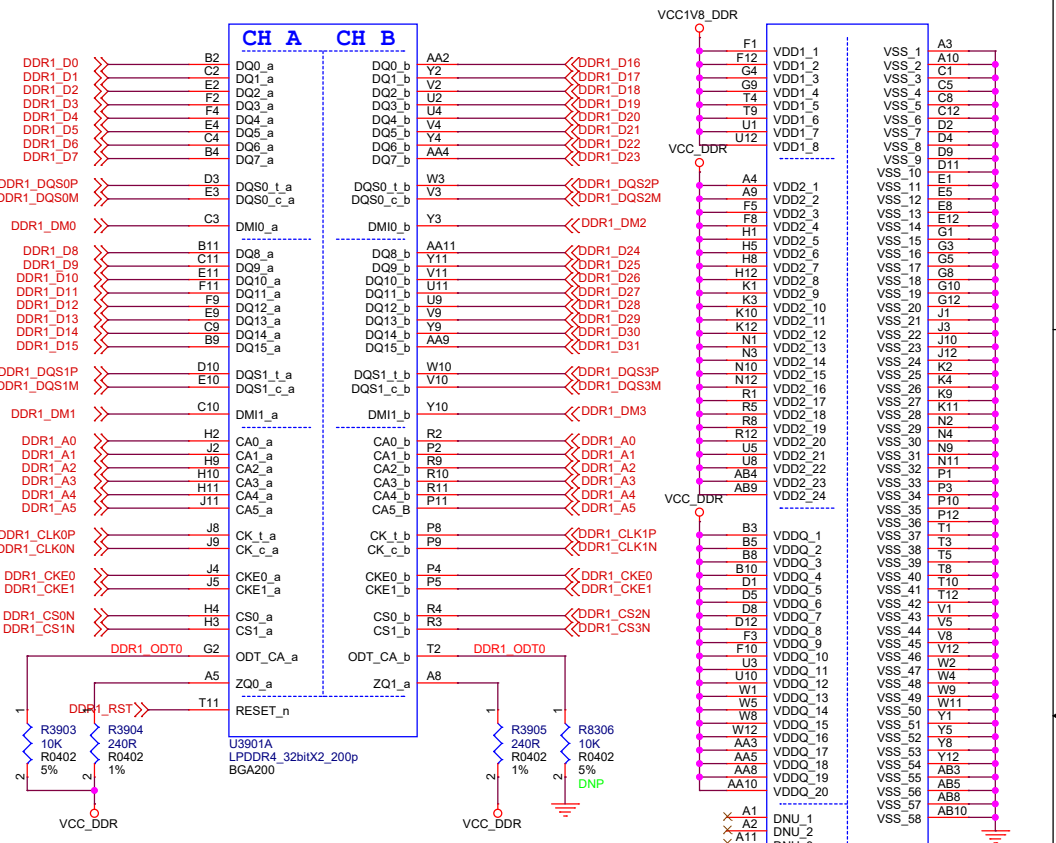
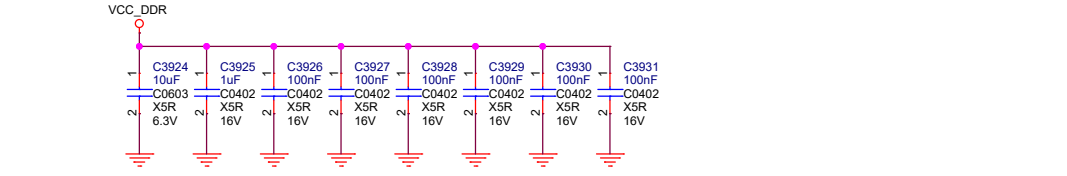
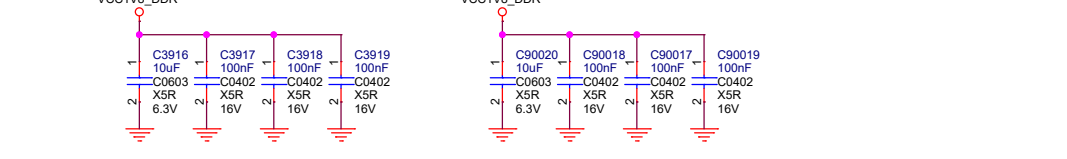
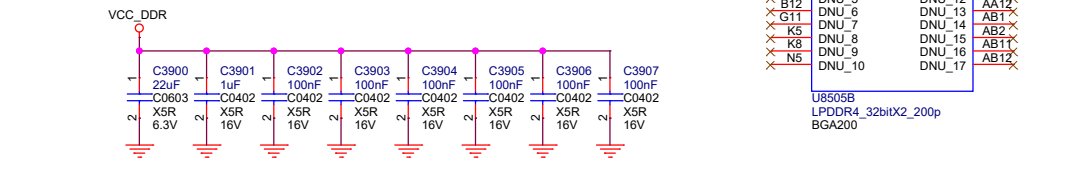
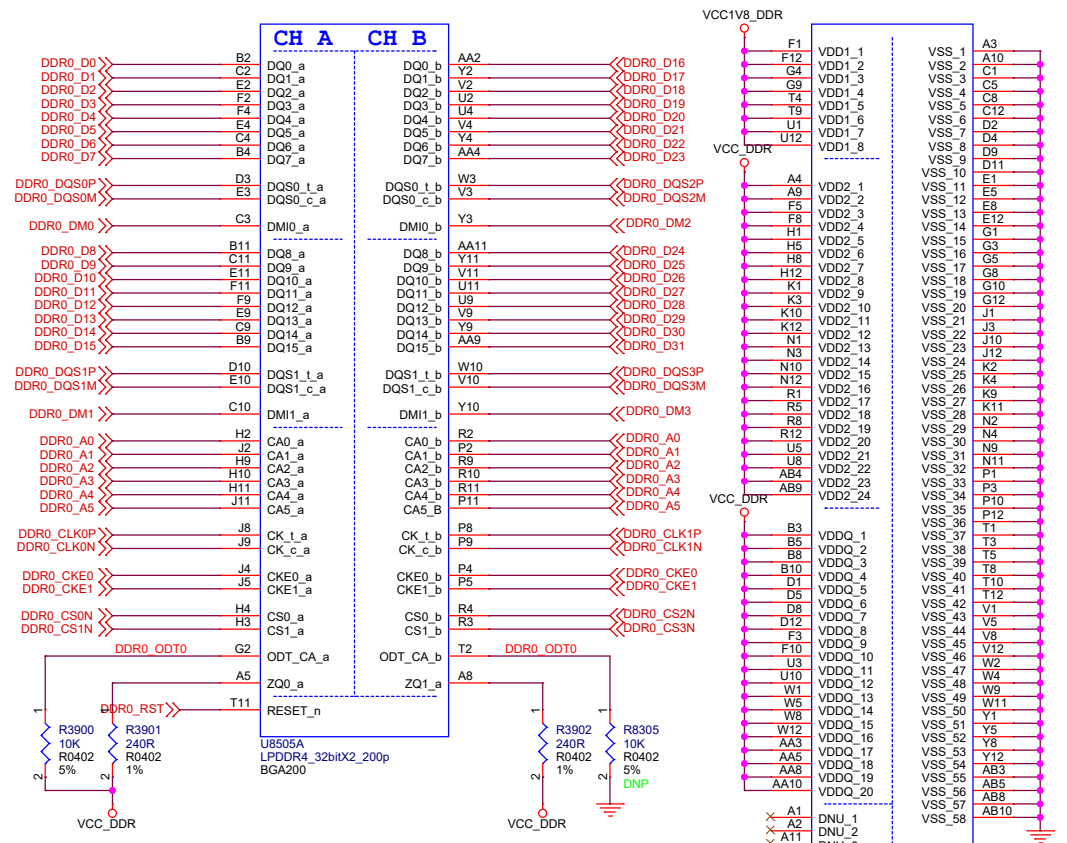

Size	Title:	Radxa ROCK 4B+	REV
A3	Page Name:	RAM-LPDDR3(178P)	1.6
Date:	Wednesday, October 11, 2023	Sheet	20 of 24

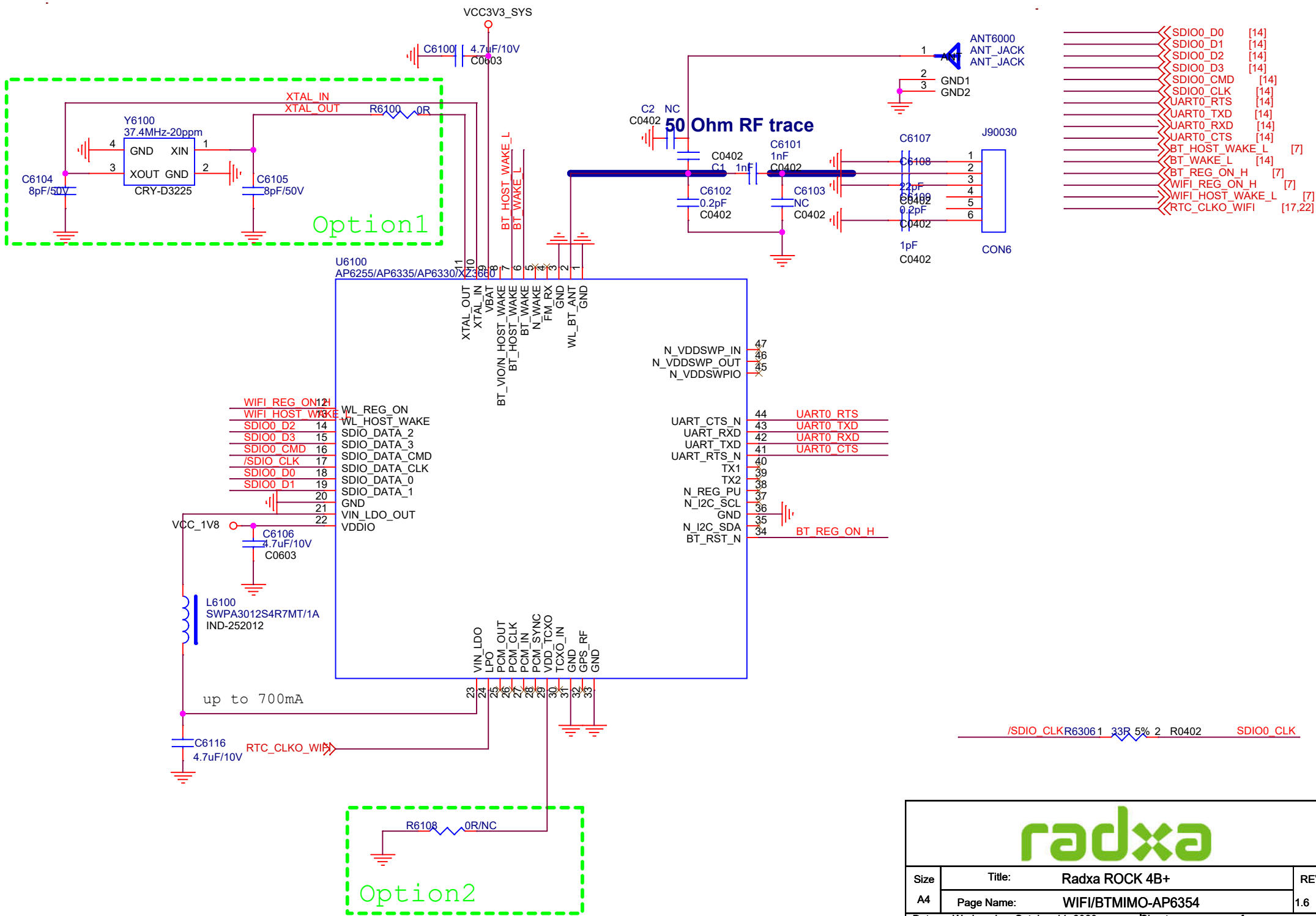

Size	Title: Radxa ROCK 4B+	REV
A4	Page Name: WIFI/BT/MIMO-AP6354	1.6
Date: Wednesday, October 11, 2023	Sheet 22 of 24	

TF CARD

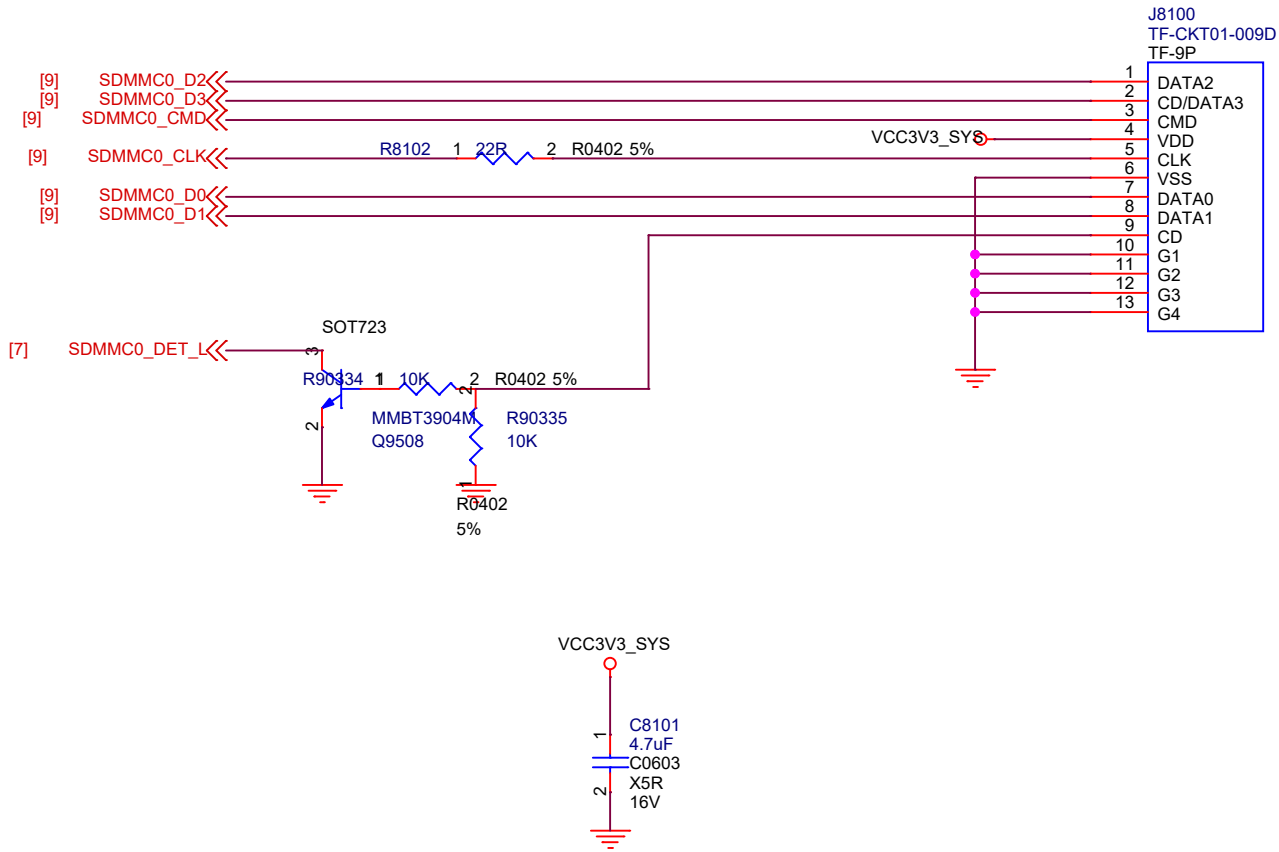

Size	Title: Radxa ROCK 4B+	REV
A4	Page Name: TF Card	1.6
Date: Wednesday, October 11, 2023	Sheet 23 of 24	

HDMI Output

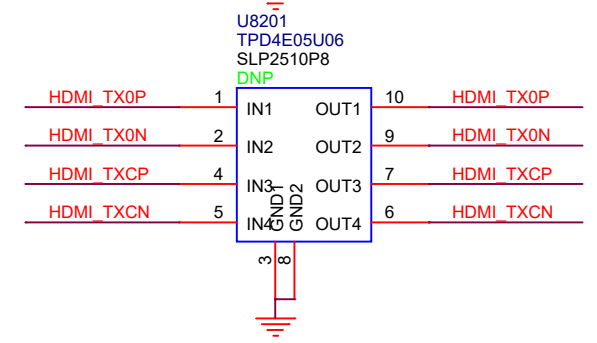
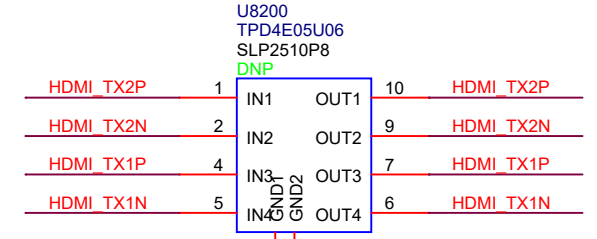
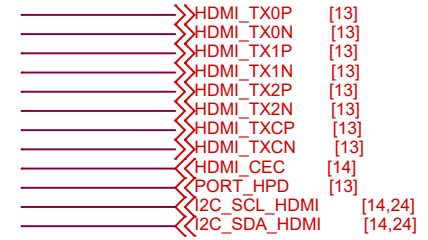
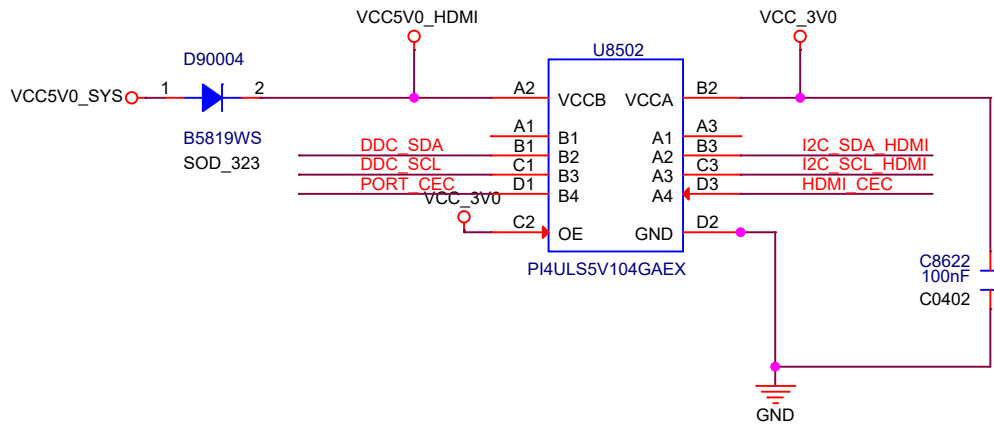
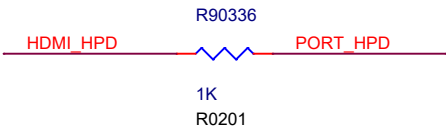
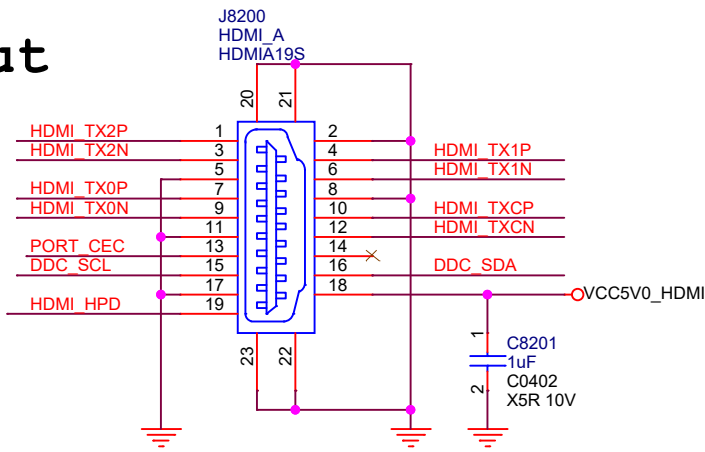



Size	Title: Radxa ROCK 4B+	REV
A4	Page Name: HDMI Output	1.6
Date:	Wednesday, October 11, 2023	Sheet 24 of 24